



Lievore,
Altherr
& Molina

actif

DCG adjustable cones circular diffusers

MADEL®

The **DCG** series diffusers are designed to be used in air-conditioning, ventilation and heating in premises from 2,6 meters high.

They can be mounted in false ceilings, or ductwork or suspended from the ceiling.

The diffusion of the air can be varied by adjusting the inner cones, changing from horizontal projection to vertical projection in accordance with the supply air temperature, providing good performance qualities for temperatures differentials up to 12°C and reducing stratification.

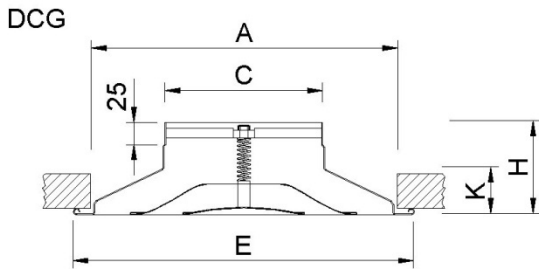

	E	A	H	K	C
160	325	303	101	44	157
200	416	385	115	58	197
250	500	464	114	57	247
315	592	564	137	80	313
355	665	630	140	83	353
400	666	630	131	74	398
450	840	793	173	106	447
500	840	793	163	97	497

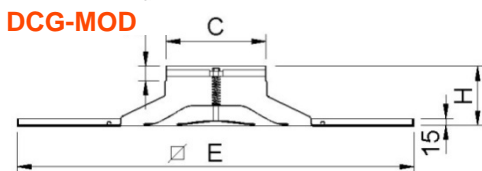

		MOD-600		MOD-625		MOD-675		
	H	C	B	E	B	E	B	E
160	101	157	12	595	12	620	15	670
200	115	197	12	595	12	620	15	670
250	114	247	12	595	12	620	15	670
315	137	313	12	595	12	620	15	670

DCG-ACTIF

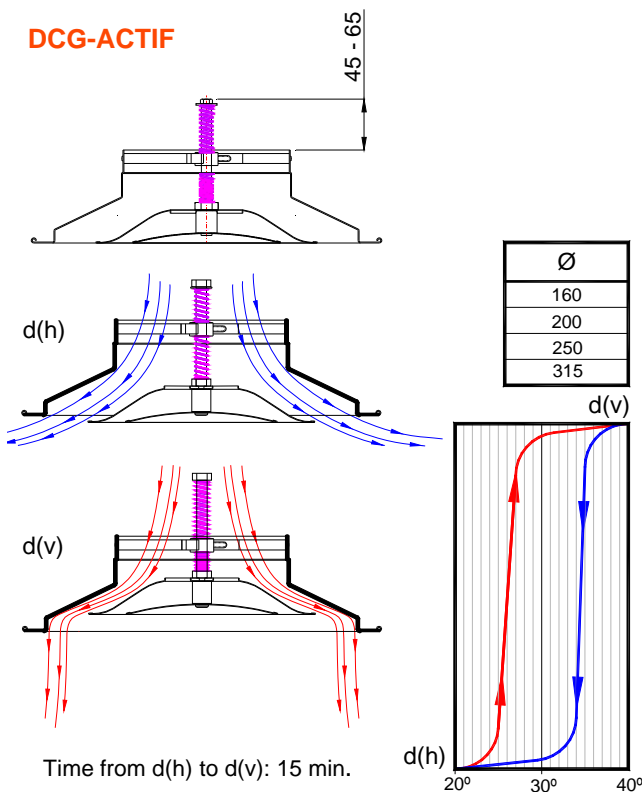

CLASSIFICATION

DCG Circular diffuser with adjustable core.

DCG-ACTIF Adjustable cone diffuser that is autonomously thermally adjustable by means of a thermodynamic spring. Designed to be used in premises with varying heights in excess of 4 m. and a temperature differential of up to 12°C. The diffusion of the air can be varied by adjusting the inner cones, changing from vertical projection to horizontal projection in accordance with the supply air temperature.

DCG-MOD Diffuser specially designed to replace a false ceiling tile.

.../T15/ Panel with angled borders to replace an angled ceiling tile profile 15 mm.

.../T24/ Panel with angled borders to replace an angled ceiling tile profile 24 mm.

MATERIAL

Diffuser constructed from aluminium and central screw from zinc coated steel.



PLDG

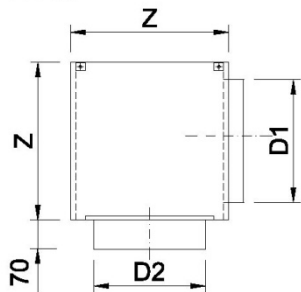

	D2	Z	D1
160	160	220	158
200	200	260	198
250	250	310	248
315	317	375	313
355	357	415	353
400	402	460	398
450	450	510	448
500	499	560	498

R3G

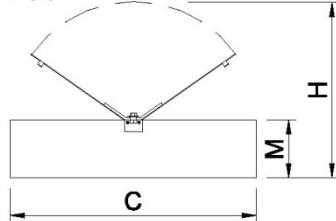

	M	H	C
160	55	119	157
200	55	139	197
250	55	164	247
315	55	198	313
355	55	218	353
400	55	241	398
450	65	274	447
500	65	299	497

R2G

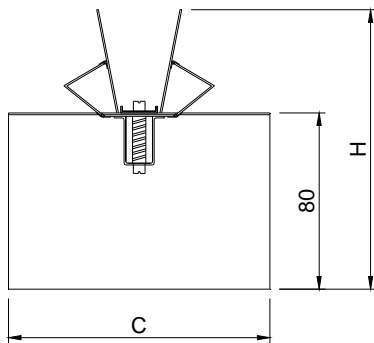

	H	C
160	145	157
200	165	197
250	190	247
315	224	313
355	244	353
400	266	398

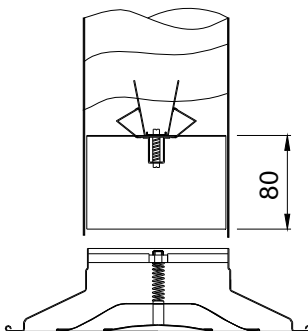

ACCESSORIES

PLDG Plenum box with a lateral circular connection. It includes supports to hang from the ceiling.

...-R Plenum box with a flow damper in the spigot.

.../S/ Plenum box with an upper circular neck connector.

.../AIS/ Thermally insulated plenum box with foam. Density 30 kg / m³ ISO 845. Thermal conductivity 20° C_0,040 W / m°K ISO 3386/1. Classified reaction to fire B-s2, d0 EN 13501-1.

R3G Flap damper assembled in the diffuser neck. Manually operated. Constructed in galvanised steel.

R2G Flap damper assembled in the diffuser neck. Screwdriver operated. Constructed in galvanised steel.

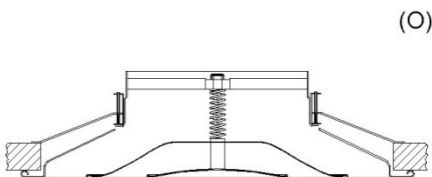
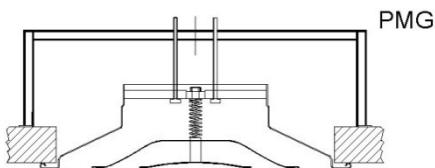
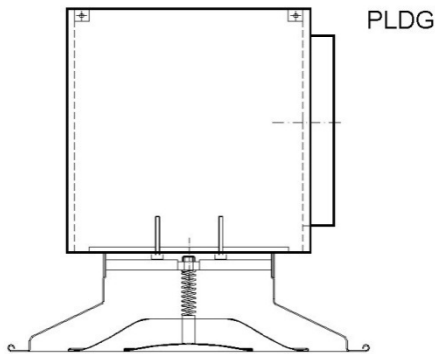
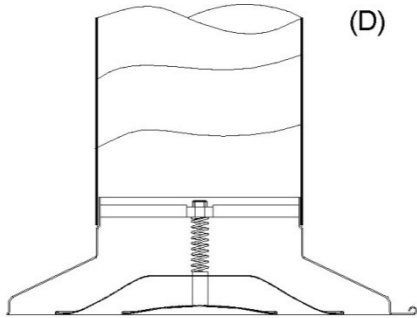

FIXING SYSTEMS

1) Connection into a circular metallic duct by means of rivets.

(P) Connection into the plenum box or crossbar by means of two central screws.

Unsuitable for DCG-ACTIF and dampers.

To regulate the flow in plenum box mounting, we suggest the PLDG-R that incorporates a damper in the plenum spigot (available up to Diam. 355)

To regulate the flow in PMG crossbar mounting, we suggest the R3G damper.

(O) Fixing with hidden screws. Suitable for mounting in false ceiling with flexible duct.

Available for DCG up to 400 mm nominal diameter. Unsuitable for DCG-ACTIF.

FINISHES

M9016 Painted white similar to RAL 9016 (85-95% gloss)

R9016S Painted white RAL 9016 semi-matt (60-70% gloss)

R9010S Painted white RAL 9010 semi-matt (60-70% gloss)

M9066 Painted grey similar to RAL 9006 (85-95% gloss)

RAL... Painted in other RAL colours

SPECIFICATION TEXT

Supply and mounting of circular diffuser with adjustable cones **DCG+PLDG M9016** dim. 160 constructed from aluminium paint in white **M9016**. With lateral circular connection plenum box **PLDG** made from galvanized steel. Manufacturer **MADEL**.



DCG SÉRIE

RECOMMENDED VELOCITY.

DCG	Vmin m/s	Vmax m/s
160	3	5,7
200	3	5,8
250	3	4,5
315	3	5,7
350	3	6,2
400	3	6
450	3	4,5
500	3	4,5

NECK AREA m2.

DCG	A k m2	Qmin m3/h	Qmax m3/h
160	0.02	215	410
200	0.0314	340	660
250	0.049	530	795
315	0.0779	835	1615
350	0.0962	1035	2175
400	0.125	1350	2730
450	0.159	1560	2655
500	0.196	1890	3160

CORRECTION FACTOR FOR DPt AND Lwa1.

DCG-R3G d(h) = +11mm

160		100%	50%
		DPt (Kp)	x1,2
	Lwa1 (Kf)	+1,4	+16

DCG-R3G d(v) = -5mm

160		100%	50%
		DPt (Kp)	x1,2
	Lwa1 (Kf)	+1,4	+16

$$DPt1 = Kp \times DPt$$

$$Lwa = Lwa1 + Kf$$

CORRECTION FACTOR FOR DPt AND Lwa1.

DCG-R3G d(h) = +10mm

200		100%	50%
		DPt (Kp)	x1,1
	Lwa1 (Kf)	+1,3	+16

DCG-R3G d(v) = -15mm

200		100%	50%
		DPt (Kp)	x1,1
	Lwa1 (Kf)	+0,8	+15

$$DPt1 = Kp \times DPt$$

$$Lwa = Lwa1 + Kf$$

NECK VELOCITY.

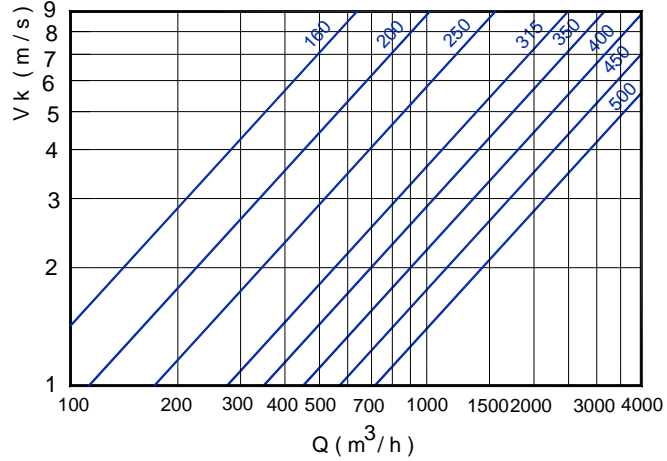

PRESSURE LOSS AND SOUND POWER LEVEL.

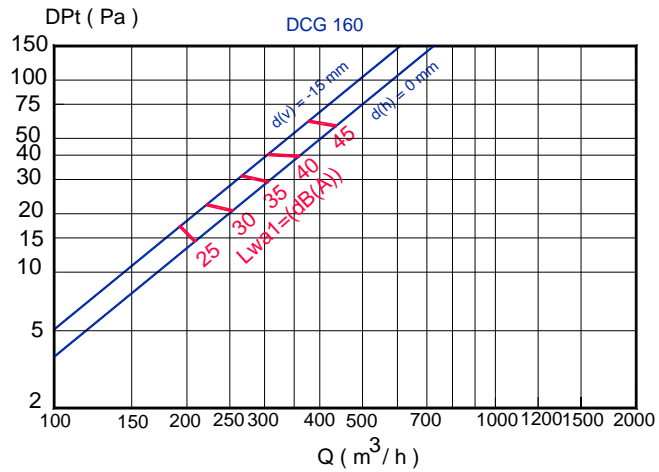

PRESSURE LOSS AND SOUND POWER LEVEL.

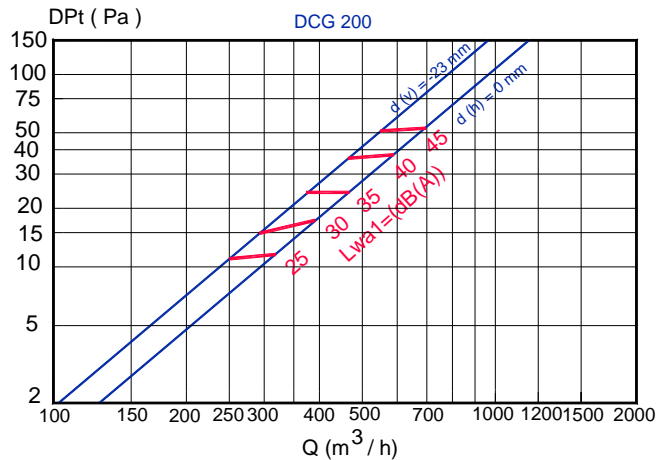

Note: In MadelMedia Octava band centre frequency in Hz.



DCG SÉRIE

PRESSURE LOSS AND SOUND POWER LEVEL.

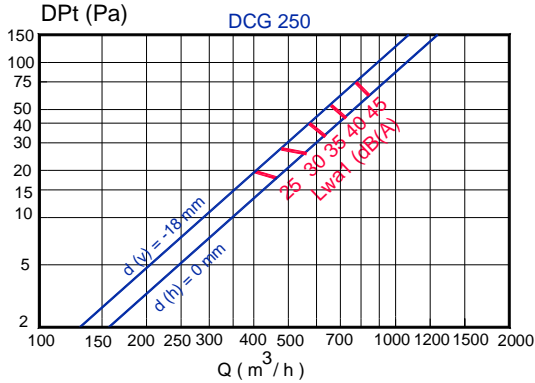

DCG-R3G d(h) = +7mm

		100%	50%
250	DpT (Kp)	x1,1	x3,7
	Lwa1 (Kf)	+3,4	+19

DCG-R3G d(v) = -17mm

		100%	50%
250	DpT (Kp)	x1,1	x3,7
	Lwa1 (Kf)	+3,8	+20

PRESSURE LOSS AND SOUND POWER LEVEL.

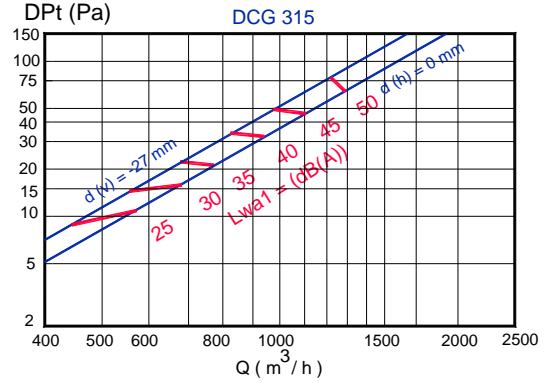

DCG-R3G d(h) = +5mm

		100%	50%
315	DpT (Kp)	x1,5	x6,5
	Lwa1 (Kf)	+1,3	+16

DCG-R3G d(v) = -22mm

		100%	50%
315	DpT (Kp)	x1,5	x6,5
	Lwa1 (Kf)	+0,6	+15

PRESSURE LOSS AND SOUND POWER LEVEL.

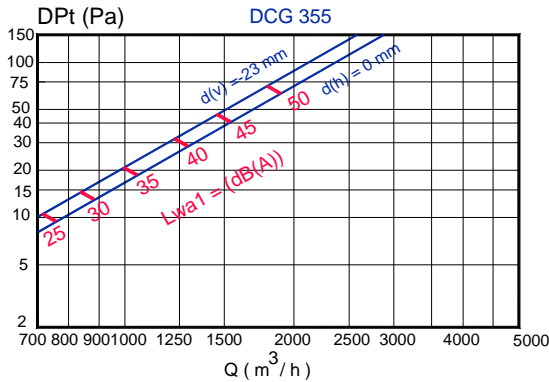

DCG-R3G d(h) = +5mm

		100%	50%
355	DpT (Kp)	x1,2	x8
	Lwa1 (Kf)	+2,2	+11

DCG-R3G d(v) = -23mm

		100%	50%
355	DpT (Kp)	x1,2	x8
	Lwa1 (Kf)	+1,6	+10

PRESSURE LOSS AND SOUND POWER LEVEL.

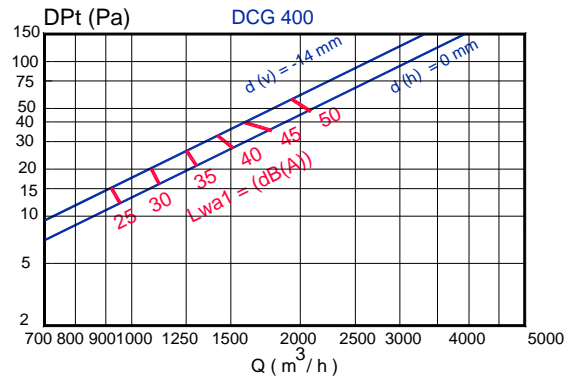

DCG-R3G d(h) = +7mm

		100%	50%
400	DpT (Kp)	x1,1	x3,4
	Lwa1 (Kf)	+2,2	+17

DCG-R3G d(v) = -20mm

		100%	50%
400	DpT (Kp)	x1,1	x3,4
	Lwa1 (Kf)	+1,6	+16

PRESSURE LOSS AND SOUND POWER LEVEL.

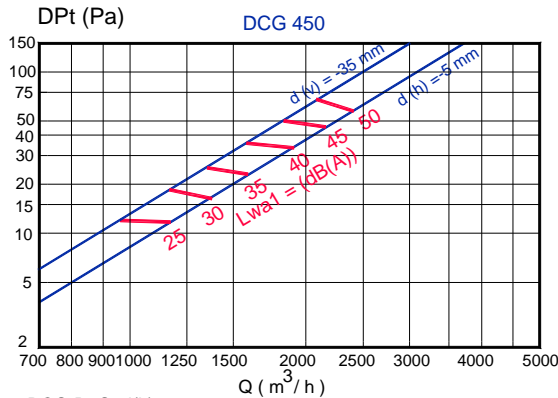

DCG-R3G d(h) = -5mm

		100%	50%
450	DpT (Kp)	x1,2	x7,1
	Lwa1 (Kf)	+3,2	+17

DCG-R3G d(v) = -30mm

		100%	50%
450	DpT (Kp)	x1,2	x7,1
	Lwa1 (Kf)	+3,5	+17

PRESSURE LOSS AND SOUND POWER LEVEL.

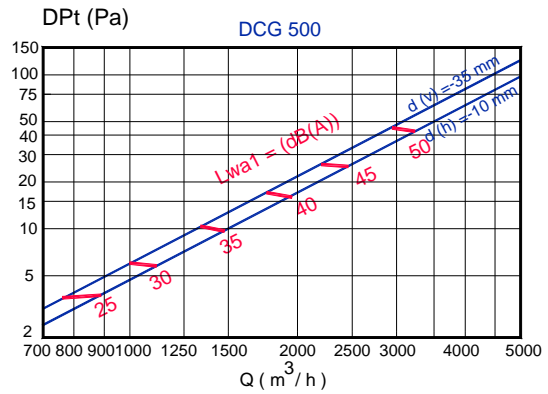

DCG-R3G d(h) = -10mm

		100%	50%
500	DpT (Kp)	x1,2	x5,8
	Lwa1 (Kf)	+2,2	+18

DCG-R3G d(v) = -35mm

		100%	50%
500	DpT (Kp)	x1,2	x5,8
	Lwa1 (Kf)	+1,5	+18

Note: In MadelMedia Octava band centre frequency in Hz.



DCG SÉRIE

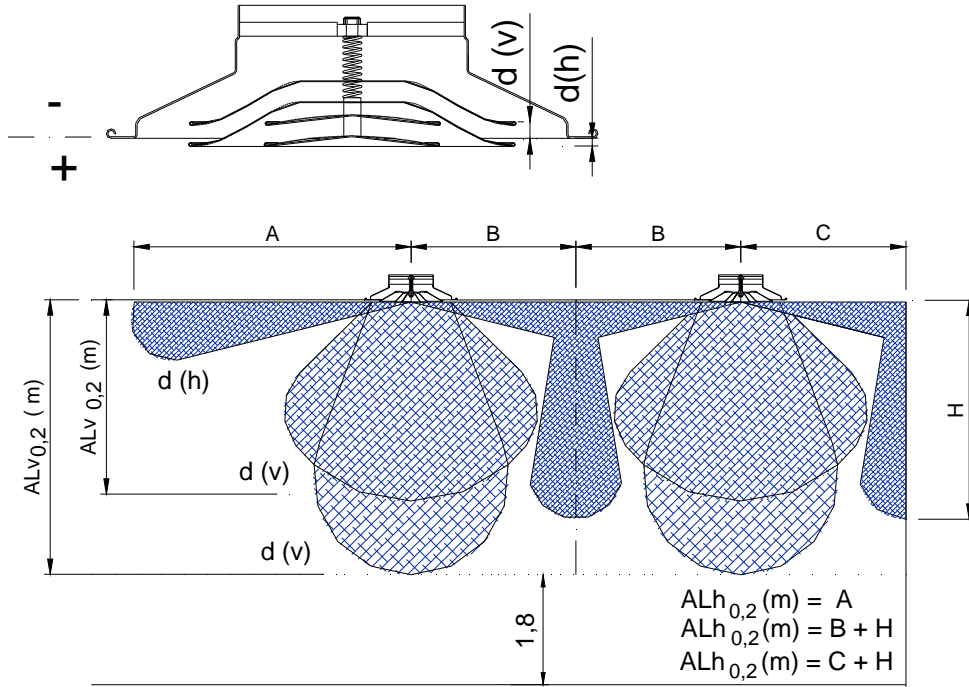

ISOTHERM THROW.

DCG 160

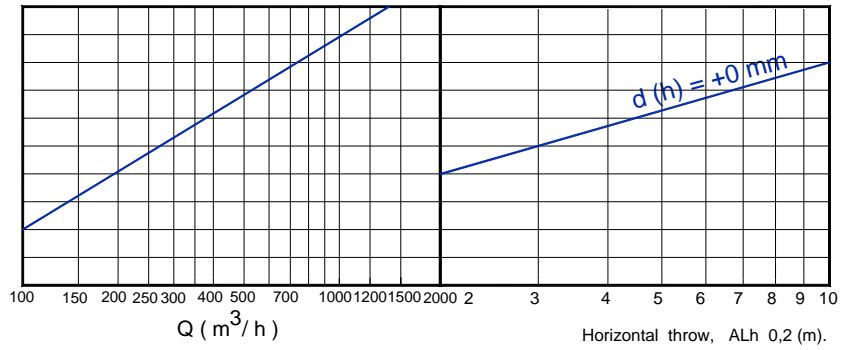

MAXIMUM VERTICAL DEPTH IN HEATING.

DCG 160

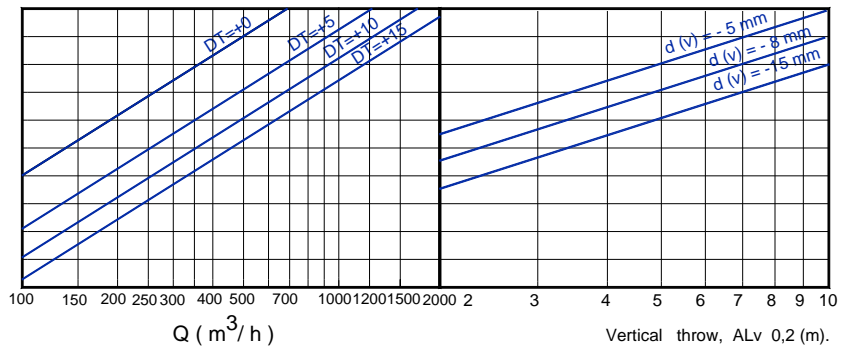



DCG SÉRIE

ISOTHERM TRHOW.

DCG 200

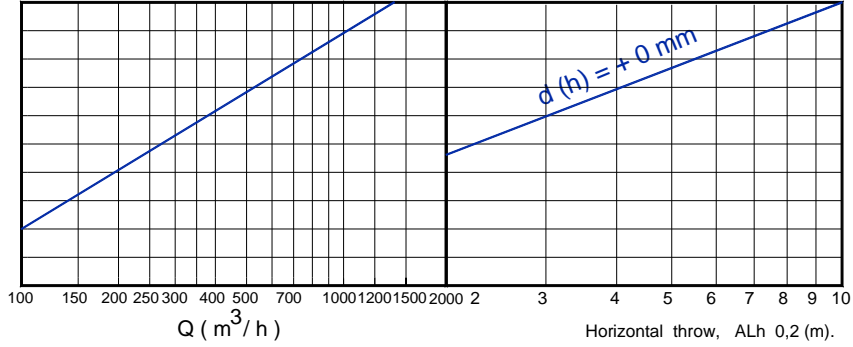

MAXIMUM VERTICAL DEPTH IN HEATING.

DCG 200

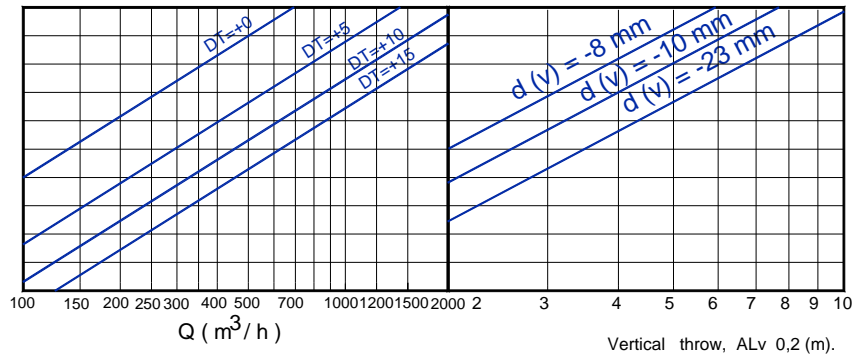

ISOTHERM TRHOW.

DCG 250

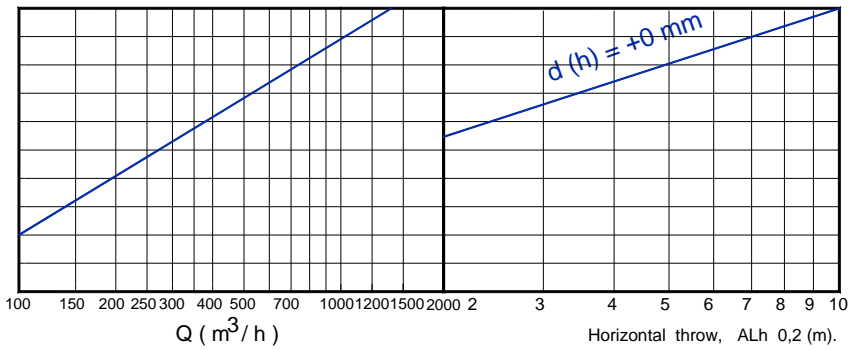

MAXIMUM VERTICAL DEPTH IN HEATING.

DCG 250

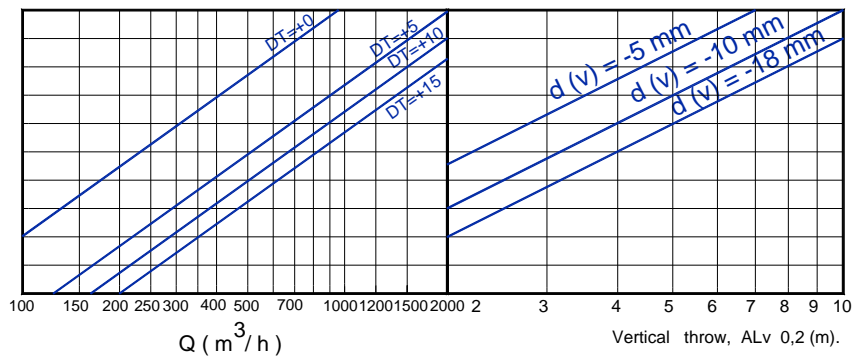



DCG SÉRIE

ISOTHERM TRHOW.

DCG 315

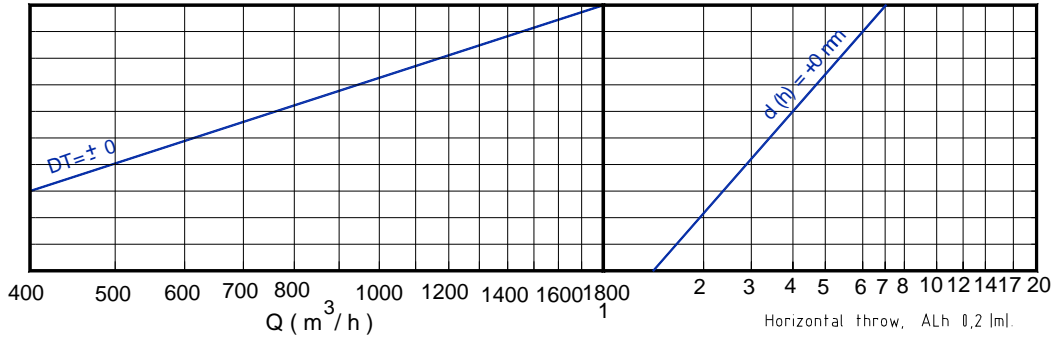

MAXIMUM VERTICAL DEPTH IN HEATING

DCG 315

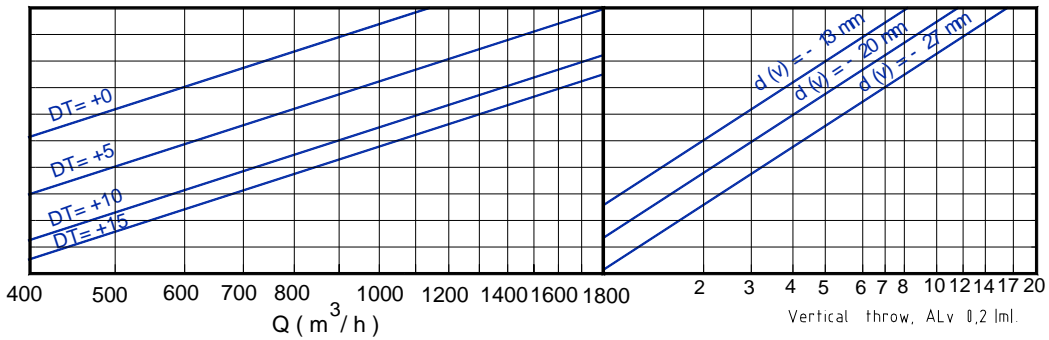

ISOTHERM TRHOW.

DCG 355

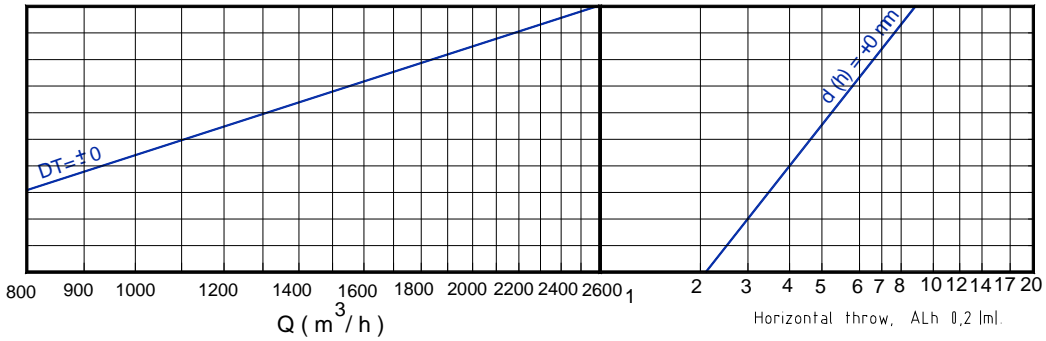

MAXIMUM VERTICAL DEPTH IN HEATING

DCG 355

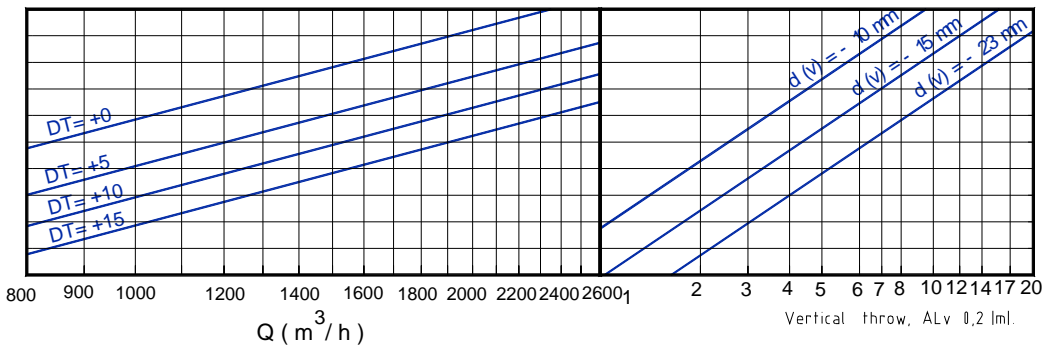



DCG SÉRIE

ISOTHERM TRHOW.

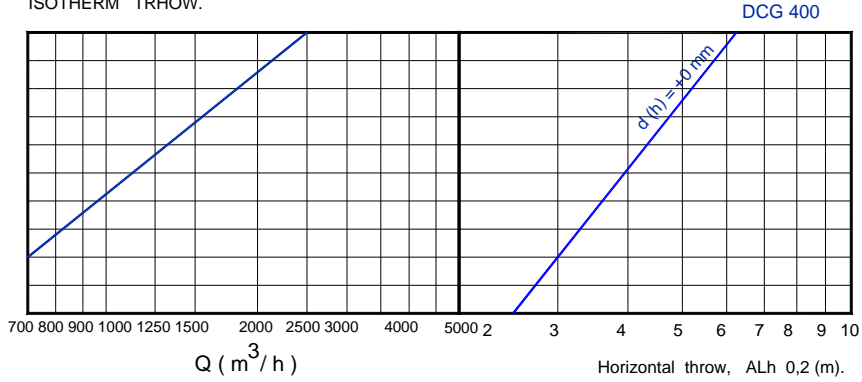

MAXIMUM VERTICAL DEPTH IN HEATING.

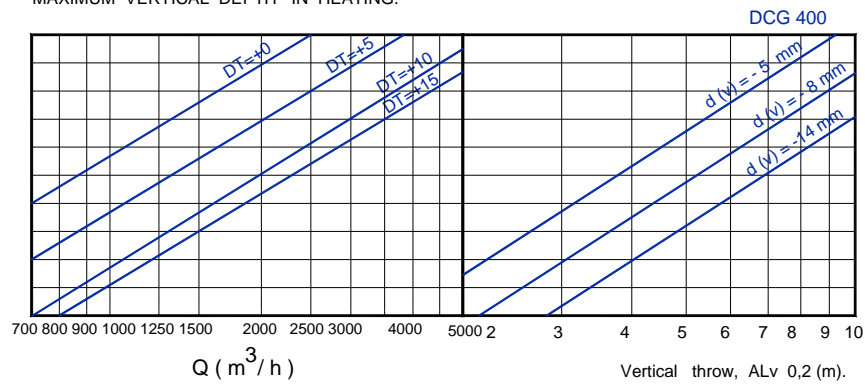

ISOTHERM TRHOW.

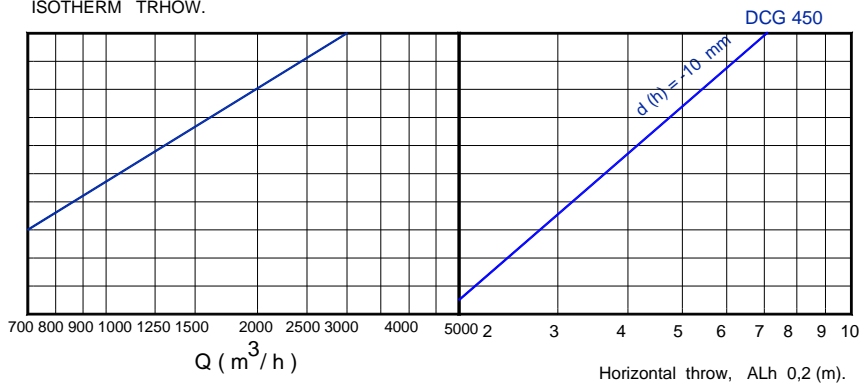

MAXIMUM VERTICAL DEPTH IN HEATING.

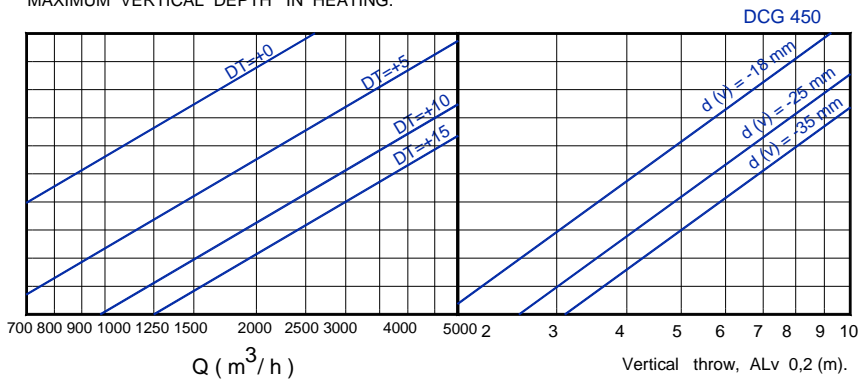



DCG SÉRIE

ISOTHERM TRHOW.

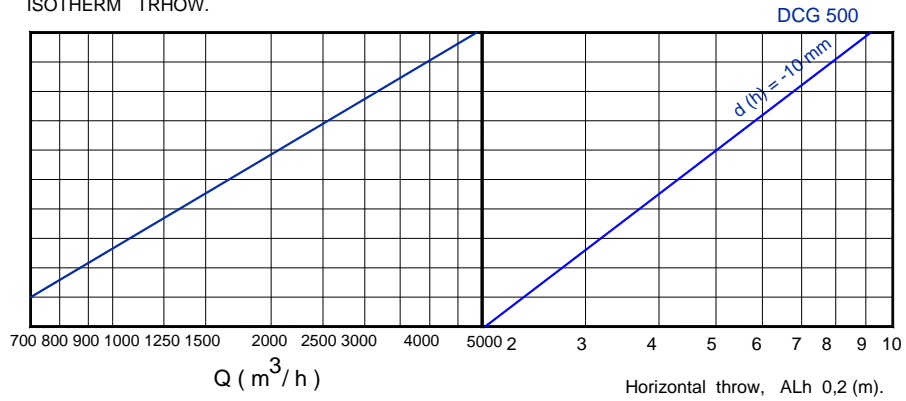

MAXIMUM VERTICAL DEPTH IN HEATING.

