

MADEL®



TAU

Напольные алюминиевые диффузоры



MADEL®

Круглые напольные диффузоры серии **TAU** предназначены для установки в театрах, аудиториях, кинозалах и подобных помещениях.

Круглые диффузоры с ползунковым регулятором клапана подачи воздуха, пылесборником и окантовкой. Устройство предназначено для установки либо в полу, либо под сиденьем.

Эти диффузоры могут использоваться при перепаде температур 6 °С с обеспечением высоких характеристик по уровню звукового давления в зоне комфорта.

TAU

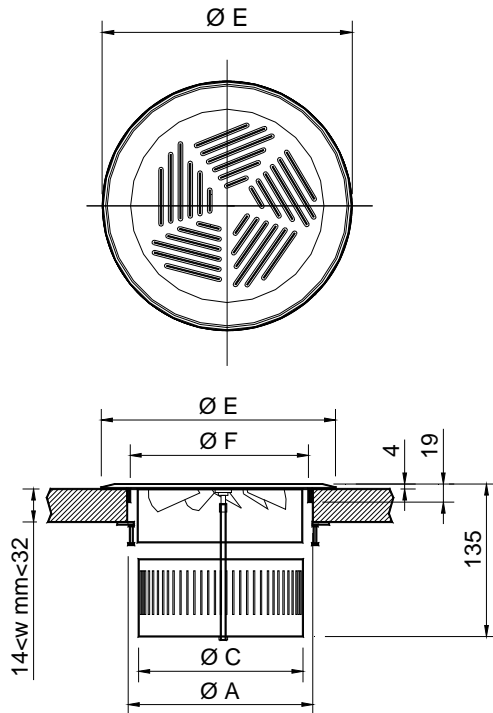

	A	E	F	C
150	150	190	140	132
200	200	240	190	182

CLASSIFICATION

TAU Floor swirl diffuser made from aluminium for creating a turbulent vertical discharge, mixing the room air.

MATERIAL

Diffuser made from aluminium.

FIXING SYSTEMS

1) Fixing by screws supplied with the diffuser.

ACCESSORIES

PLAU Plenum with lateral circular connection, incorporating brackets for ground fixing. Made of galvanized steel.

...-R Volume damper in the spigot.

.../AIS/ Thermally insulated plenum with foam: Density 30 kg / m³ ISO 845. Thermal conductivity 20° C_0,040 W/m²K ISO 3386/1.

Classified reaction to fire B-s2, d0 EN 13501-1.

PLAU

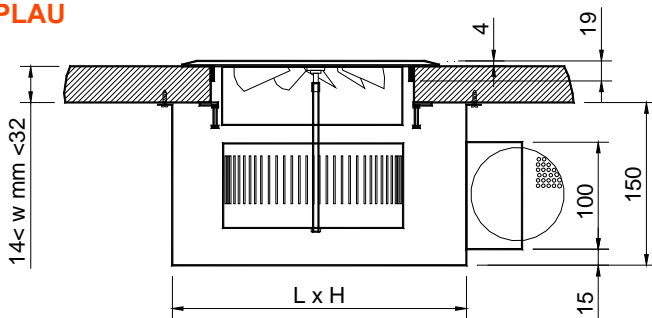

	L	H
150	225	225
200	275	275

FINISHES

1) Natural aluminium.

RAL... Painted in other RAL colors.

SPECIFICATION TEXT

Supply and mounting of floor circular swirl diffuser with sliding volume damper and dust collector series **TAU dim. 150** constructed from natural aluminium. Manufacturer **MADEL**.

RAL colors



Assembly instructions

1.- Nominal diameter concrete slab opening :

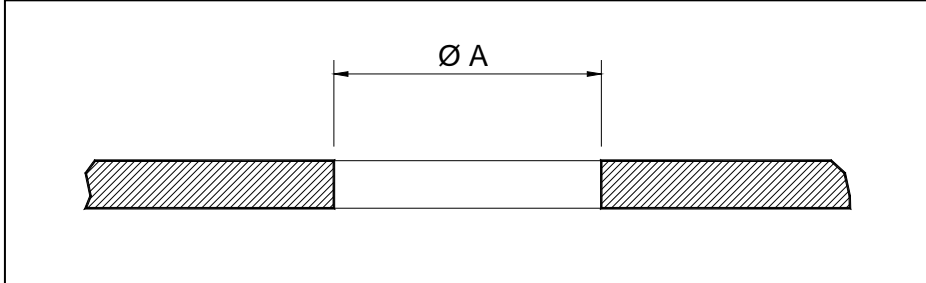

2.- Fit the screws on the mounting frame :

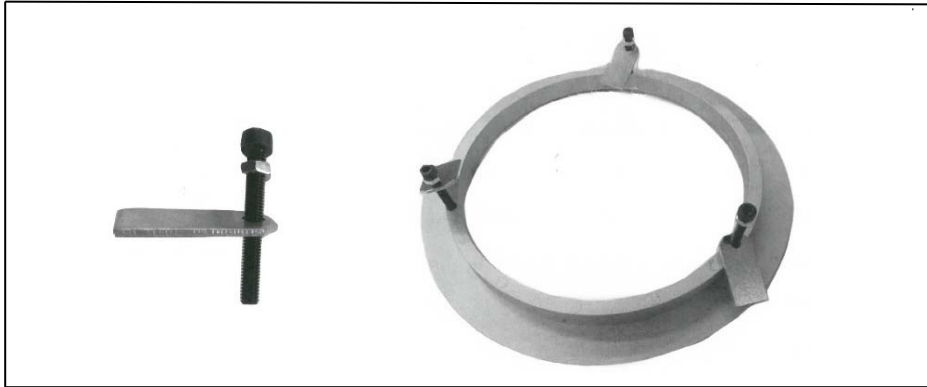

3.- When using a PLAU type plenum, screw it onto the lower part of the concrete slab :

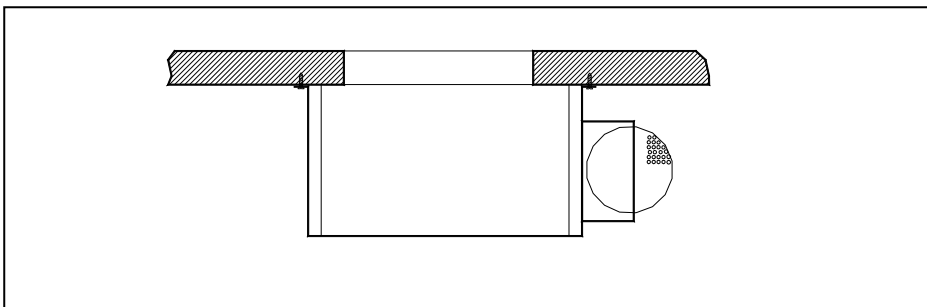

4.- Finally fix the frame of the TAU, screw and place the diffuser :

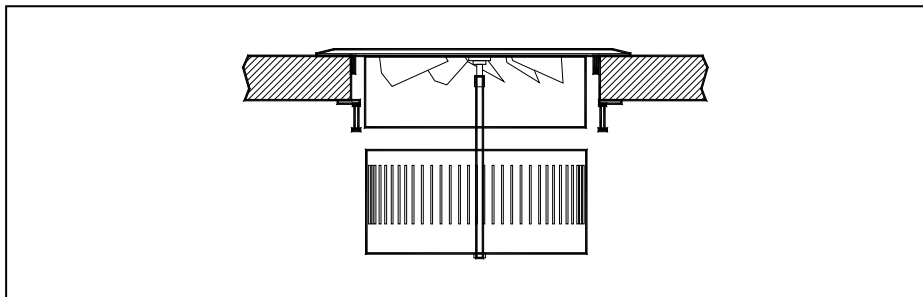



TAU - 150

MADEL®

PRESURE LOSS AND SOUND POWER LEVEL

RECOMMENDED VELOCITY

	min m/s	max m/s
	0,4	0,85

FREE FACE AREA (m2)

	m2	min m3/h	max m3/h
150	0.018	30	57

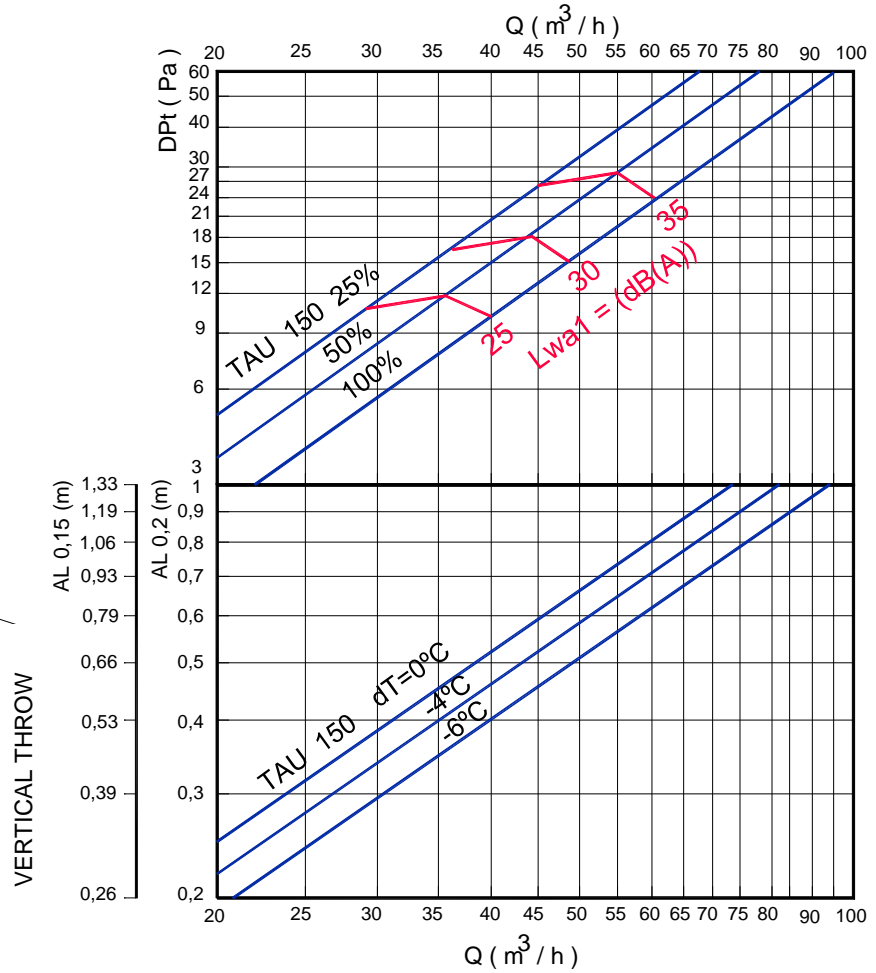
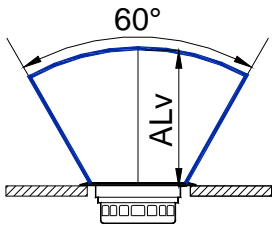
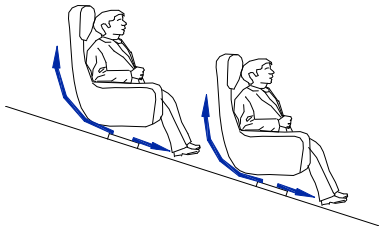

Speed profile TAU 150

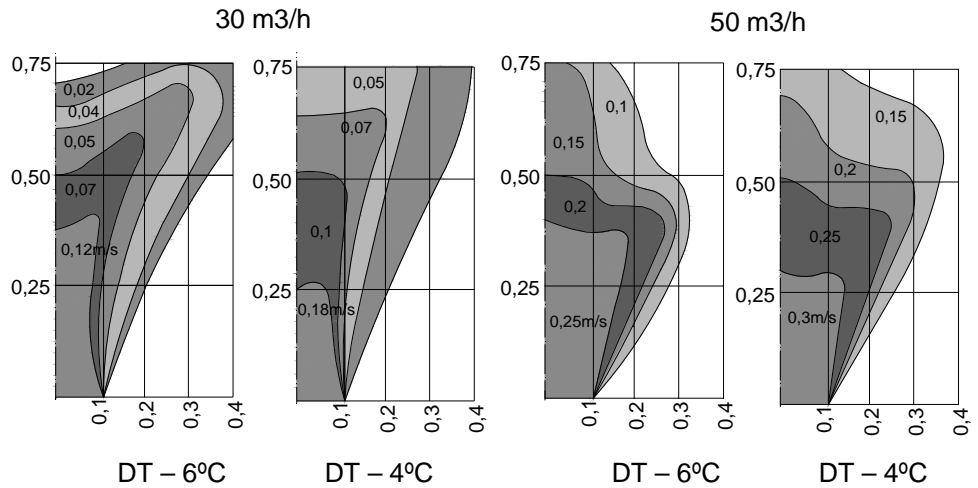
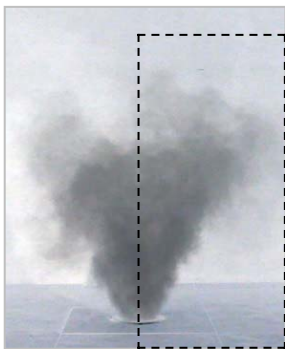



RECOMMENDED VELOCITY

	min m/s	max m/s
	0,4	0,85

FREE FACE AREA (m2)

	m2	min m3/h	max m3/h
200	0.0314	60	100

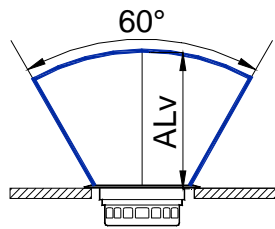
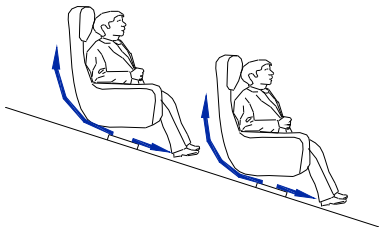

VERTICAL THROW

PRESURE LOSS AND SOUND POWER LEVEL

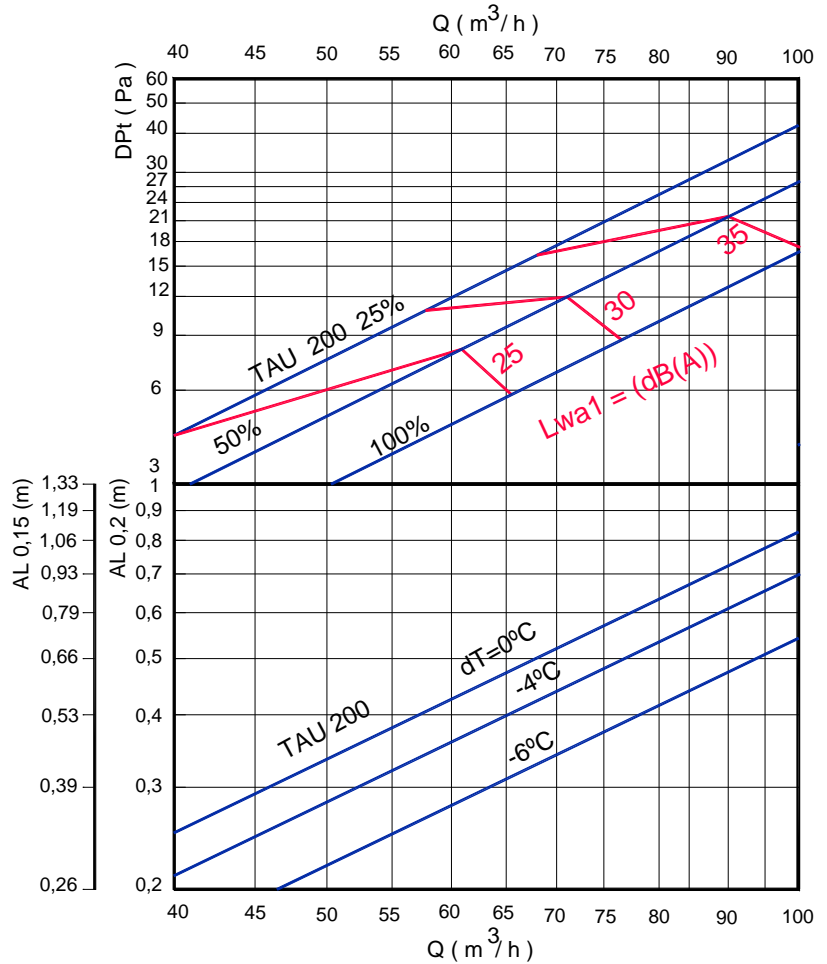

Speed profile TAU 200

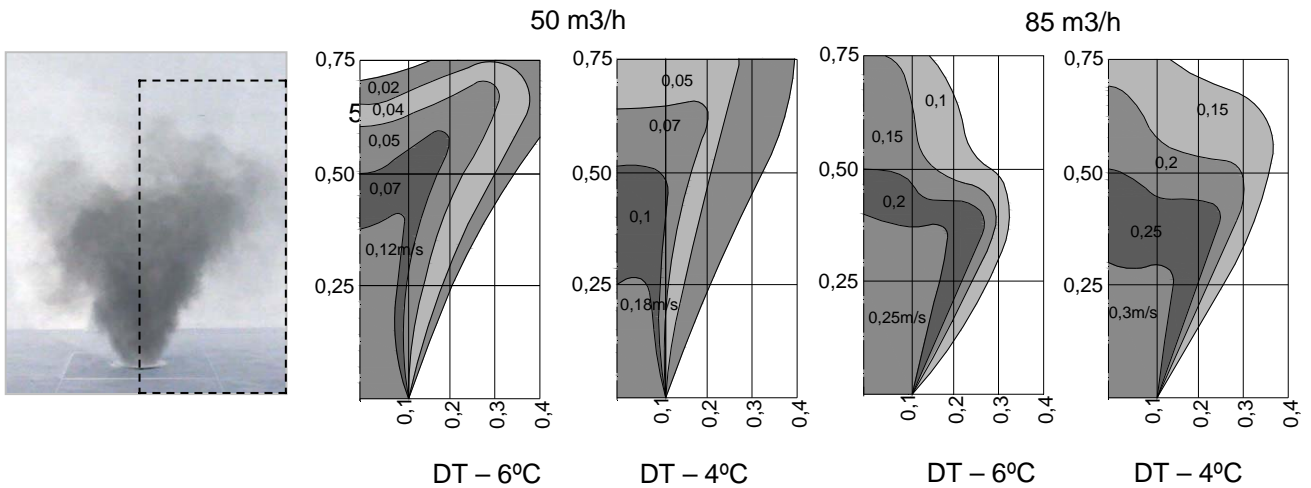

Acoustic data by octave bands



Figure 1 Connection of the air duct to the bleachers



Figure 2 Model of bleachers with 8 diffusers

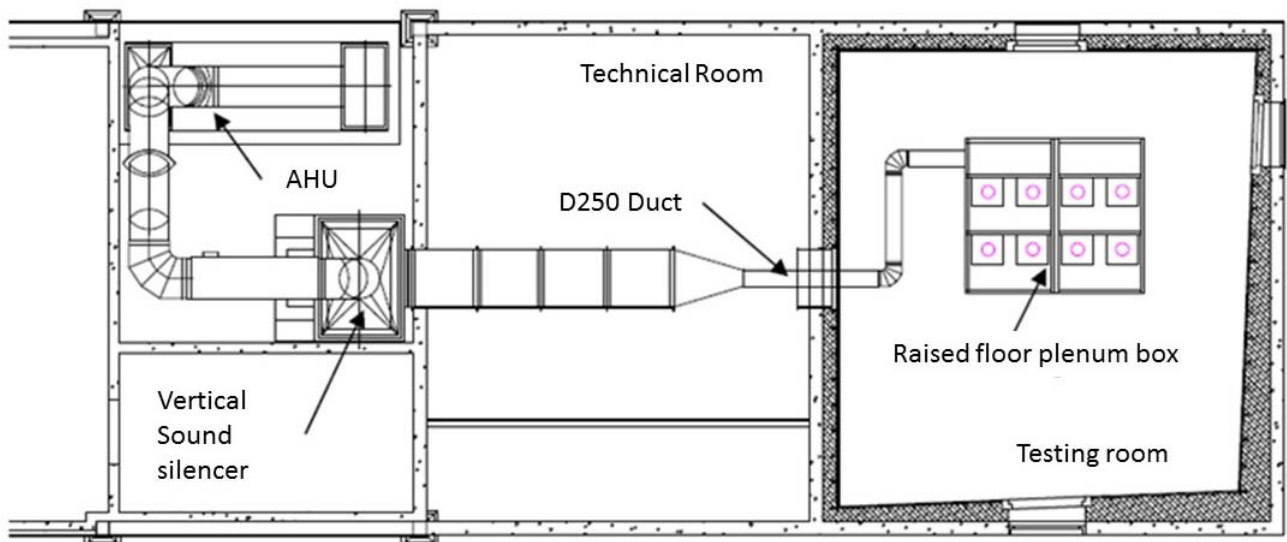

Figure 3 Principle scheme

TAU- 150

Q	Sound power level in dB (A). Octava band centre frequency in Hz											Pa
m3/h	63	125	250	500	1000	2000	4000	8000	GLOBAL	NC	NR	Dpt
30	<8	8	15	17	13	6	<8	2	20	15	20	5
40	5	13	20	22	18	11	5	7	25	20	25	10
50	12	20	27	29	25	18	12	14	32	30	30	16
60	15	23	30	32	28	21	15	17	35	30	35	23

TAU-200

Q	Sound power level in dB (A). Octava band centre frequency in Hz											Pa
m3/h	63	125	250	500	1000	2000	4000	8000	GLOBAL	NC	NR	Dpt
60	7	11	17	17	13	5	4	7	22	20	20	5
75	14	18	24	24	20	12	11	14	29	25	30	8
90	18	22	28	28	24	16	15	18	33	30	35	13
100	21	25	31	31	27	19	18	21	36	35	35	17