

KOO multi-buses à longue portée

Les multi-buses de la série **KOO** ont été conçus pour être utilisés dans les installations de CVC.

- Buses réglables individuellement manuellement.
- Fixation murale pour moyenne / longue portée.
- Convient à tout type de locaux avec un différentiel de température jusqu'à 12°C.

Avantages produit :

- Flexibilité totale de la direction du flux d'air.
- Esthétique avant-gardiste.
- Taux d'induction élevé pour minimiser la stratification de l'air.



- Bureaux
- Halls
- Centres commerciaux

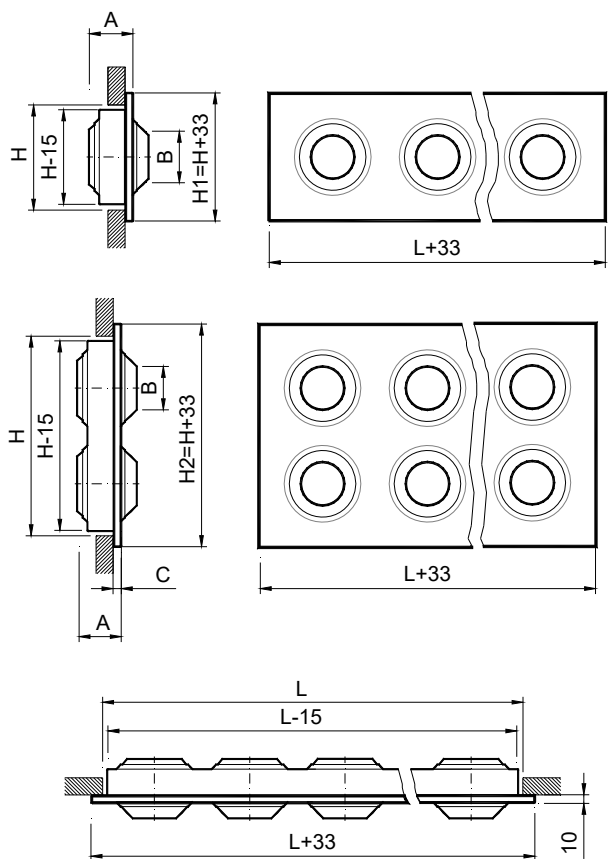

CLASSIFICATION

KOO Multi-Buse orientable manuellement.

MATERIEL

Buses construites en aluminium et plaque en acier galvanisé. Joint de rotation en matériau solide et résistant.

FINITIONS

R9016S Peinture blanche RAL 9016 (60-70% brillance)

R9010S Peinture blanche RAL 9010 (60-70% brillance)

R9016B Peinture blanche RAL 9016 (85-95% brillance)

R9006M Peinture couleur alu RAL 9006 (20-30% brillance)

RAL... Peinture autres couleurs RAL.

Lx100	n Jets	Lx200	n Jets
200x100	2	200x200	4
300x100	3	300x200	6
400x100	4	400x200	8
500x100	5	500x200	10
600x100	6	600x200	12
700x100	7	700x200	14
800x100	8	800x200	16
900x100	9	900x200	18
1000x100	10	1000x200	20

Lx150	n Jets	Lx300	n Jets
300x150	2	300x300	4
450x150	3	450x300	6
600x150	4	600x300	8
750x150	5	750x300	10
900x150	6	900x300	12
1050x150	7	1050x300	14
1200x150	8	1200x300	16

Ø	LxH	B	A	H1	H2	UN.	
80	Lx100	44	46	133	-	L/H	1 line
	Lx200	44	46	-	233	4x(L/H)	2 lines
125	Lx150	61	63	183	-	L/H	1 line
	Lx300	61	63	-	333	4x(L/H)	2 lines



PLRO/S/

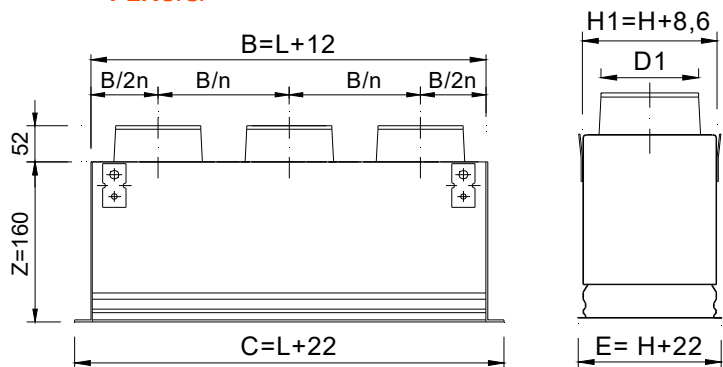

PLRO /L/

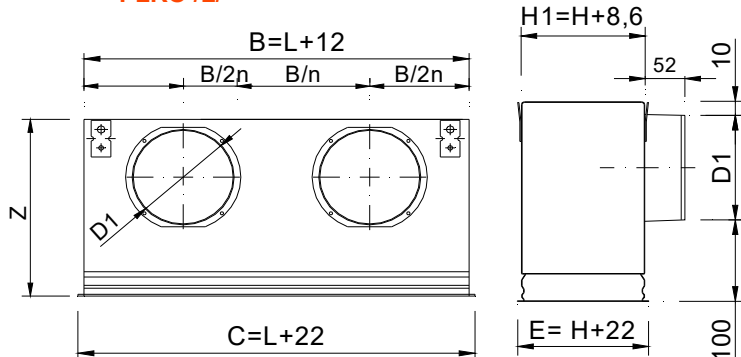

L x H mm	PLRO/S/ D1 Ø	PLRO/L/ D1 Ø	L x H mm	PLRO/S/ D1 Ø	PLRO/L/ D1 Ø
200x100	1/98	1/123	200x200	1/198	1/198
300x100	1/98	1/158	300x200	1/198	1/198
400x100	1/98	1/158	400x200	1/198	1/248
500x100	1/98	1/198	500x200	1/198	1/248
600x100	2/98	1/198	600x200	2/198	1/248
700x100	2/98	2/198	700x200	2/198	2/198
800x100	2/98	2/198	800x200	2/198	2/198
900x100	2/98	2/198	900x200	2/198	2/248
1000x100	2/98	2/198	1000x200	2/198	2/248
300x150	1/123	1/198	300x300	1/248	1/248
450x150	1/123	1/198	450x300	1/248	1/313
600x150	2/123	1/198	600x300	1/248	1/313
750x150	2/123	2/198	750x300	2/248	2/248
900x150	2/123	2/198	900x300	2/248	2/313
1050x150	2/123	2/198	1050x300	2/248	2/313
1200x150	3/123	3/198	1200x300	2/248	3/313

IEK

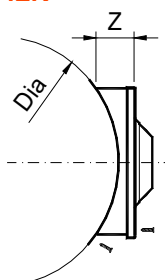

IEK - Diam. - L x H	Diam. duct Ø	Z
IEK- Ø - L x 100	200 - 1600	48
IEK- Ø - L x 150	250 - 1600	48
IEK- Ø - L x 200	315 - 1600	65
IEK- Ø - L x 300	400 - 1600	95

ACCESSOIRES

CM Cadre de montage construit en acier galvanisé (fournis en 4 éléments) La dimension de la reservation LxH doit être augmentée de 8 mm.

PLRO Plénum à raccordement circulaire. Il comprend des supports pour suspension au plafond. Construit en acier galvanisé.

.../S/ Piquage circulaire arrière.

.../L/ Piquage circulaire latéral.

...-R Régulateur de débit sur le piquage de connexion.

.../AIS/ Isolation thermique intérieure au moyen d'une mousse. Densité 30 kg/m³ ISO 845. Conductivité thermique 20° C_0,040 W/m²K. ISO 3386/1. Classification réaction au feu: B-s₂,d₀ EN 13501-1.

IEK Greffe pour assemblage longitudinal en conduit circulaire visible. Nécessite fixation (T)

SYSTÈMES DE FIXATION

(S) Clips. Nécessite cadre de montage CM.

(T) Vis apparentes. Obligatoire pour montage au plafond.

PRESCRIPTION

Fourniture et pose de multi-buse orientable manuellement dans toutes directions série **KOO+CM (S) R9016S** dim. LxH, construite en aluminium et plaque en acier galvanisé peint couleur blanc RAL 9016 (60-70% brillance) ou autre à décider par la D.F., fixation par clips (S) et cadre de montage. **Marque MADEL.**



KOO series

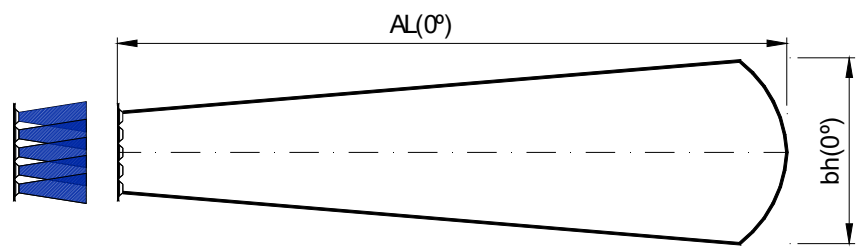
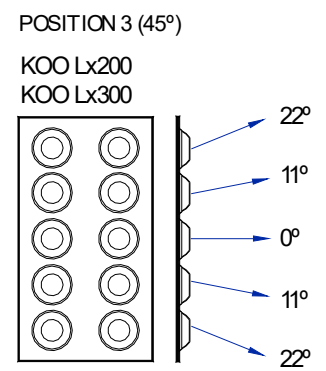
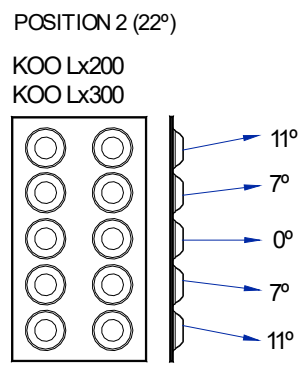
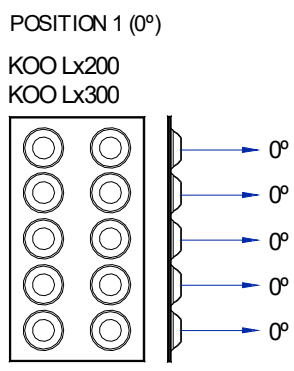
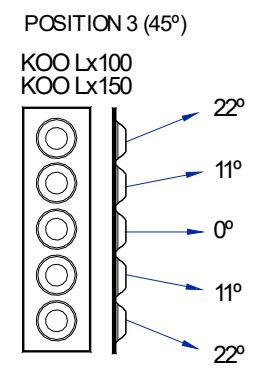
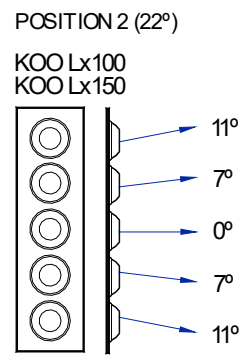
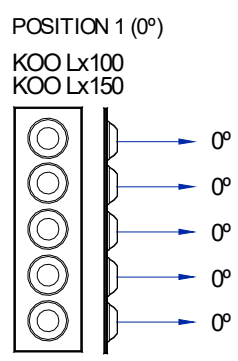

POSITION 1 (0°)
 $AL(0°) = AL$
 $bh(0°) = 0,28 \times AL$

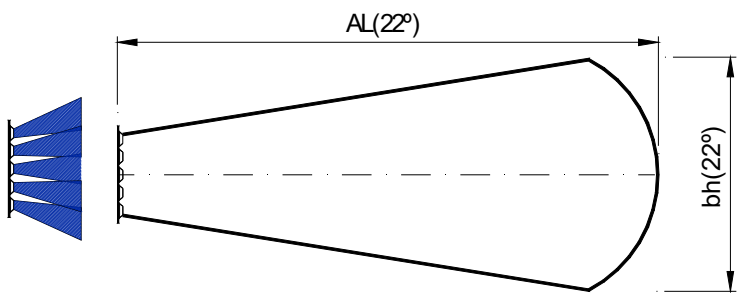

POSITION 2 (22°)
 $AL(22°) = 0,7 \times AL$
 $bh(22°) = 0,68 \times AL$

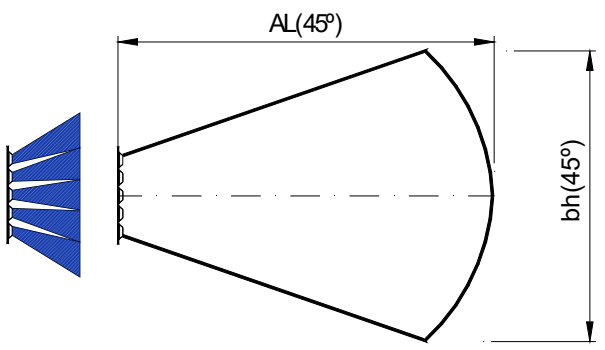

POSITION 3 (45°)
 $AL(45°) = 0,5 \times AL$
 $bh(45°) = 1,15 \times AL$



VITESSE RECOMMANDÉE

	Vfmin m/s	Vfmax m/s
Lx100	2,5	10,7
Lx200	2,5	9,8

SECTION LIBRE DE SORTIE D'AIR (m²).

LxH		Afree (m ²)	Qmin (m ³ /h)	Qmax (m ³ /h)
200x100	2x1	0,0028	25	140
300x100	3x1	0,0043	39	210
400x100	4x1	0,0057	51	270
500x100	5x1	0,0072	65	330
600x100	6x1	0,0086	77	375
700x100	7x1	0,01	90	420
800x100	8x1	0,0114	103	465
900x100	9x1	0,0129	116	510
1000x100	10x1	0,0144	130	555
200x200	2x2	0,0057	51	265
300x200	3x2	0,0086	77	400
400x200	4x2	0,0114	103	520
500x200	5x2	0,0144	130	640
600x200	6x2	0,0172	155	720
700x200	7x2	0,02	180	795
800x200	8x2	0,022	198	870
900x200	9x2	0,0258	232	950
1000x200	10x2	0,0288	259	1025

VITESSE LIBRE, PERTE DE CHARGE, PUISSANCE SONORE
et PORTÉE

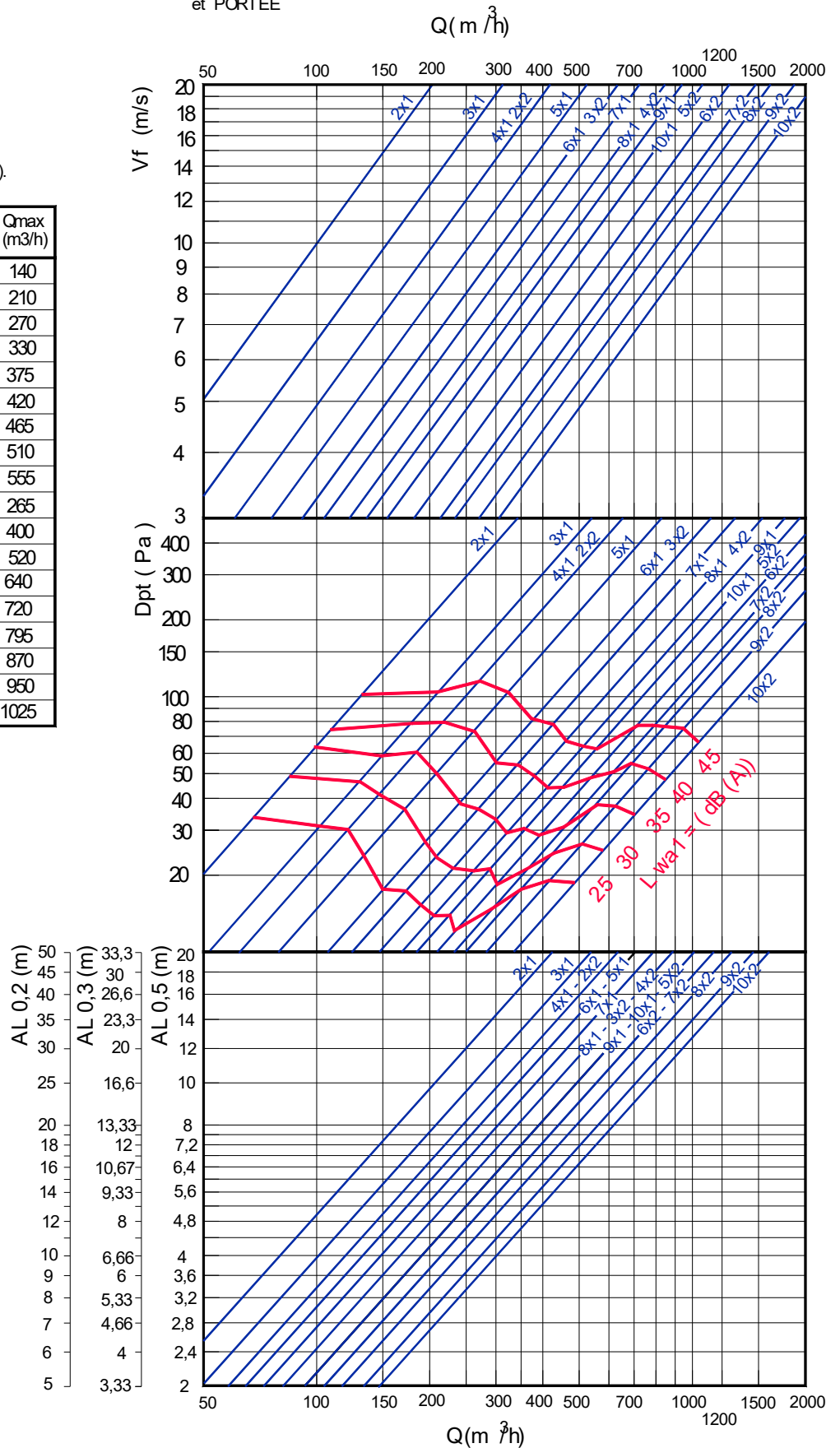

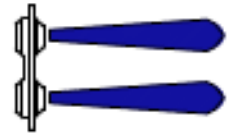

VITESSE RECOMMANDÉE

	Vfmin m/s	Vfmax m/s
Lx150	2,5	10,6
Lx300	2,5	11

SECTION LIBRE DE SORTIE D'AIR (m2).

LxH		Afree (m2)	Qmin (m3/h)	Qmax (m3/h)
300x150	3x1,5	0,0056	50	250
450x150	4,5x1,5	0,0084	76	370
600x150	6x1,5	0,0112	101	495
750x150	7,5x1,5	0,014	126	590
900x150	9x1,5	0,0168	151	680
1050x150	10,5x1,5	0,0196	176	770
1200x150	12x1,5	0,0224	202	860
300x300	3x3	0,0112	101	435
450x300	4,5x3	0,0168	151	650
600x300	6x3	0,0224	202	870
750x300	7,5x3	0,028	252	1105
900x300	9x3	0,0336	302	1340
1050x300	10,5x3	0,0392	353	1575
1200x300	12x3	0,0448	403	1810

VITESSE LIBRE, PERTE DE CHARGE, PUISSANCE SONORE
et PORTÉE

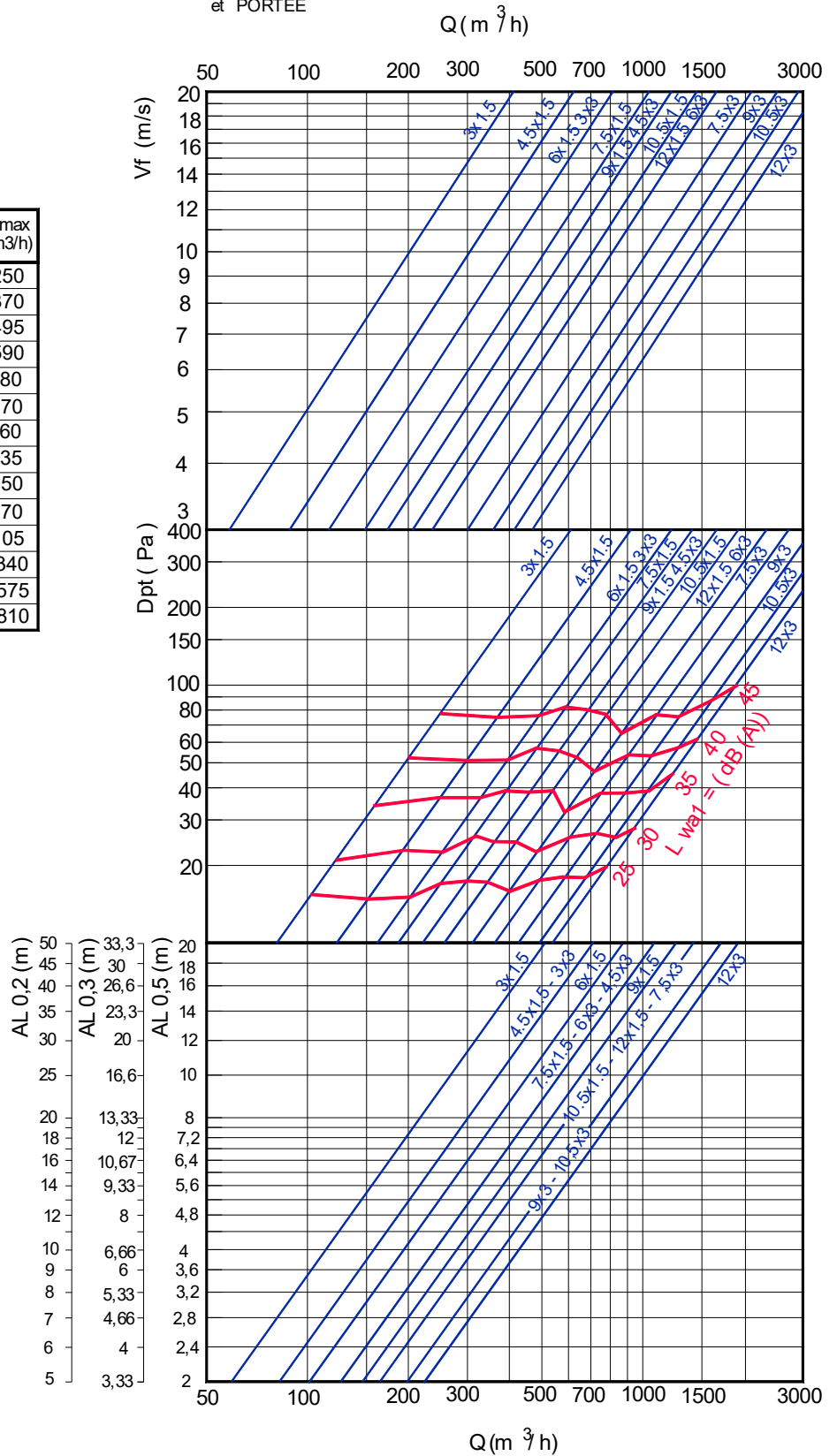

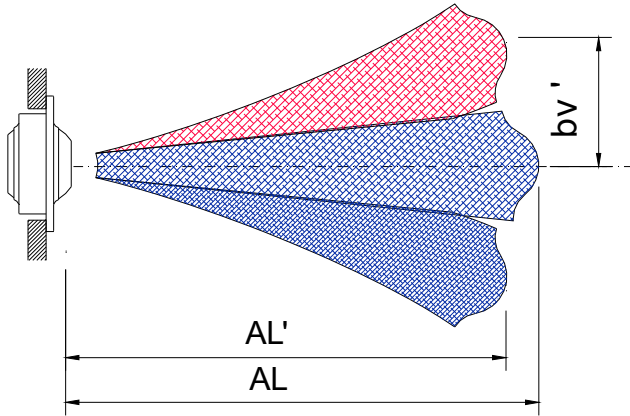

Z1	Z2	Z3	Z4
200x100	500x100	800x100	700x200
300x100	600x100	900x100	800x200
400x100	700x100	1000x100	900x200
200x200	300x200	400x200	1000x200
300x150	450x150	500x200	1050x150
	600x150	600x200	1200x150
	300x300	750x150	600x300
		900x150	750x300
		450x300	900x300
			1050x300
			1200x300

FACTEUR DE CORRECTION POUR
LA DIFFUSION VERTICALE (bv)
POUR DT (-).

FACTEUR DE CORRECTION DE
LA PORTÉE (L0,2) DT (-).

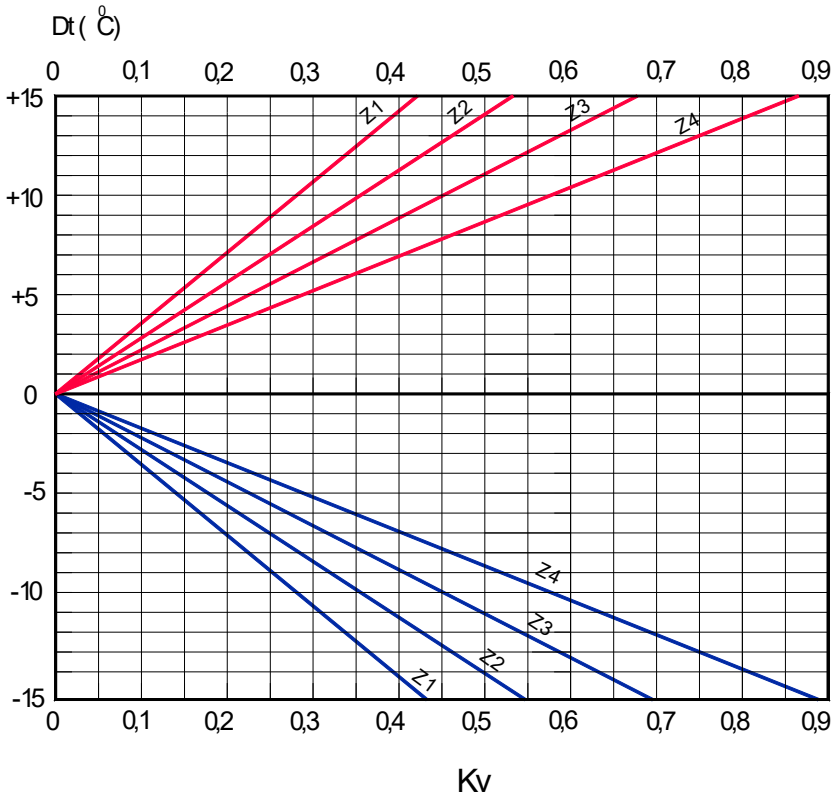

$$bv' = Kv \times AL$$

Kv = Facteur de correction pour la diffusion verticale.

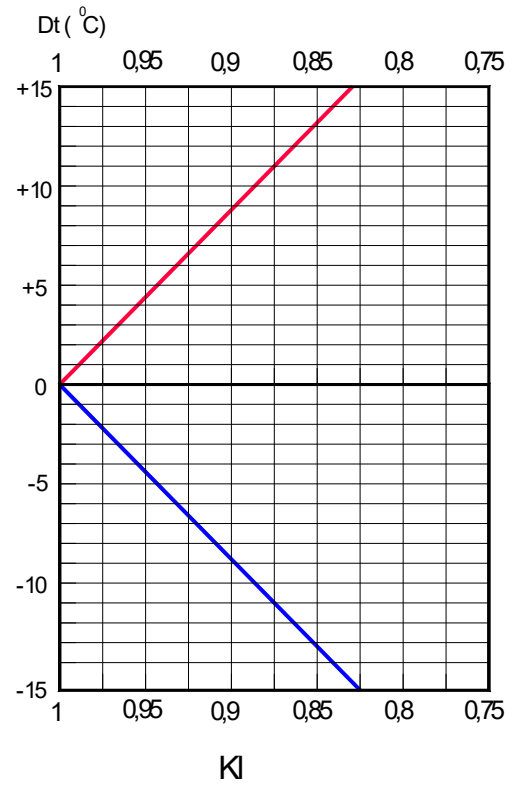

$$AL' = KI \times AL$$

KI = Facteur de correction pour la portée.



KOO series

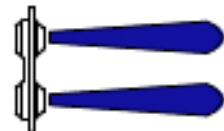

COEFFICIENT DE CORRECTION DE LA PORTÉE VERTICALE (A_v) DT

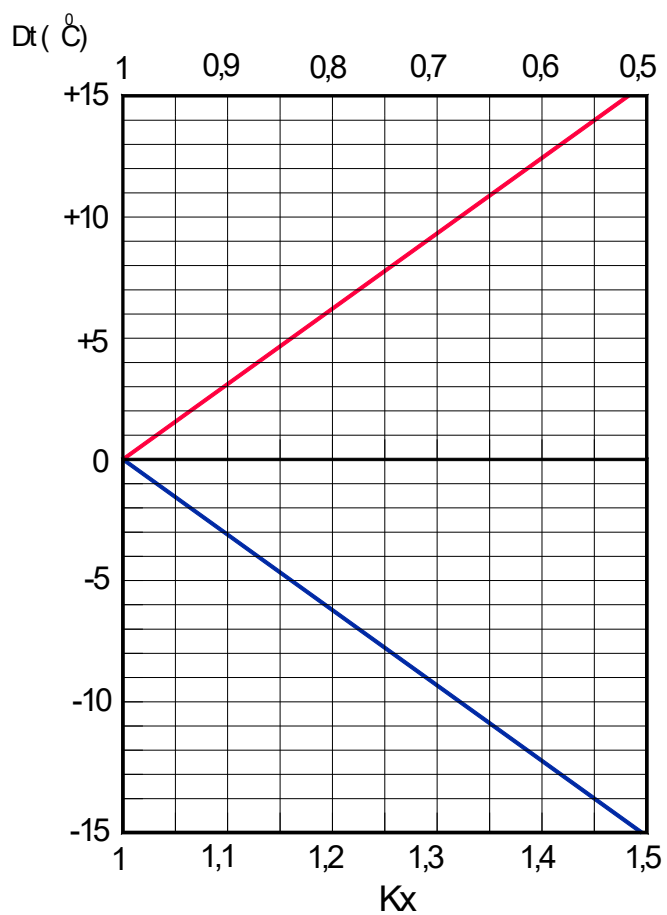
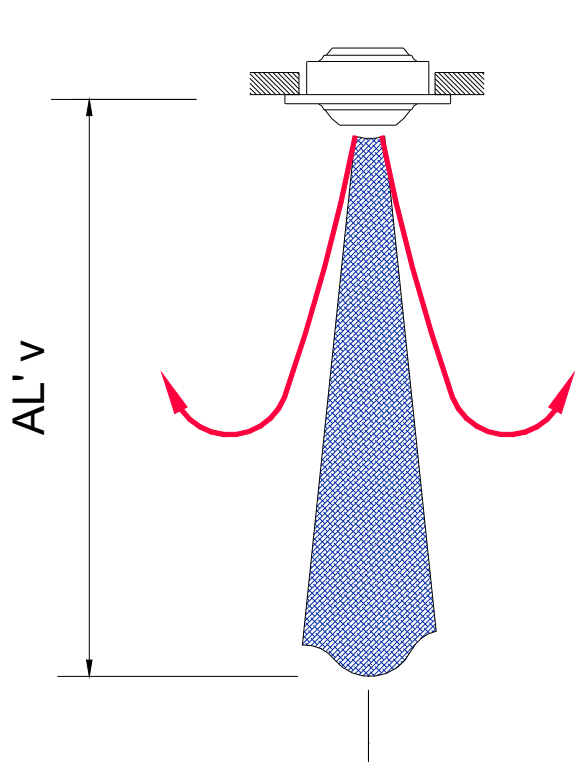

$$AL'v = Kx \times AL$$