



SVA-R compuertas rectangulares de VAV

MAD^{EL}

Regulador de caudal para conducto rectangular en instalaciones de Volumen de Aire Variable (VAV). Las compuertas **SVA-R** permiten ajustar el caudal de aire de un ramal o de una sala en función de una señal 0-10 V suministrados por un regulador de temperatura. La señal de consigna enviada por el regulador de sala, posiciona el actuador para ajustar el caudal a la necesidad del recinto.

Es posible la modificación a posteriori de los caudales V min y V max mediante controlador remoto.

SVA-R/AIS/

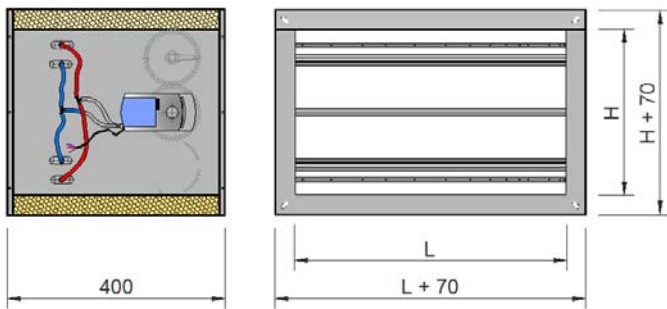

SVA-R

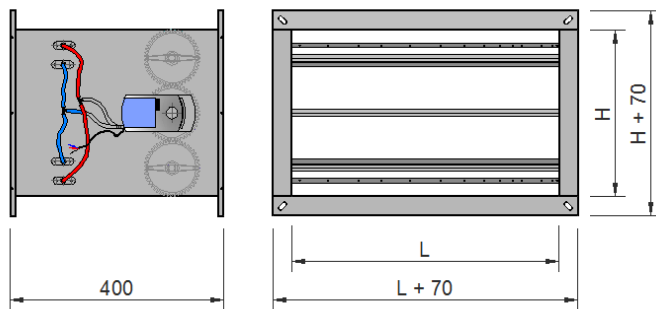

RDG



CR24



TEXTO DE PRESCRIPCIÓN

Sum. y col. de compuerta rectangular de VAV con cruz de medición de presión diferencial, para la regulación del caudal de aire **SVA-R/M/CON 0-10/ HxL (mm) Vmin Vmax**, modo de trabajo del regulador tipo Master **/M/** y control proporcional 0-10 V **/CON 0-10/**. Construida en acero galvanizado, cruz de medición en aluminio, racors en ABS, tubos de medición en silicona y junta de estanqueidad de la lama en EPDM. Marca **MADEL**.

CLASSIFICACIÓN

SVA-R Compuerta rectangular de regulación VAV. Caudal de aire máximo (Vmax) y mínimo (Vmin) de regulación tarado en fábrica según especificaciones del cliente.

.../M/ Modo de trabajo del regulador tipo Master.

.../S/ Modo de trabajo del regulador tipo Slave.

.../CON 0-10/ Control proporcional 0-10 V.

.../CON 3P/ Control 3 puntos.

/AIS/ Aislado termoacústicamente.

MATERIAL

Carcasa en acero galvanizado, cruz de medición de presión diferencial en aluminio, racors en ABS y tubos de medición del actuador en silicona Roja / azul. Junta de estanqueidad de la lama en EPDM.

ACCESORIOS

RDG 400 (SIEMENS)

Controlador de temperatura Ambiente proporcional 0... 10 vcc aliment. 24vac con display digital retroiluminado, selector confort/eco/paro actuadores de compuerta proporcionales y Controladores compactos para cajas VAV.

CR24-A1 (BELIMO)

Controlador de temperatura Ambiente proporcional 0... 10 vcc aliment. 24vac.

RDG 400KN (SIEMENS)

CR24-B1 (BELIMO)

Comunicación KNX estándar para Integrar en BMS.

CONEXIÓN A CONDUCTOS DE AIRE

- Tomar las precauciones para asegurar que el flujo de aire llegue uniformemente a la compuerta y evitar su instalación con presencia de vibraciones.
- La dimensión interior de los conductos de aire, NO será inferior a la dimensión interior de la compuerta.
- Respetar la alineación de la compuerta al embridar los conductos.
- Prolongar el conducto para minimizar el ruido generado en la compuerta.

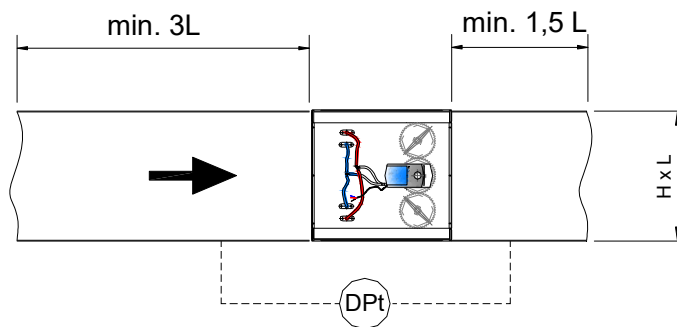

Área libre de sección y pérdida de carga: Dpt (Pa) , Ak (m²)

HxL	200	300	400	500	600	700	800
100	0,02	0,03	0,04	0,05	0,06	0,07	0,08
150	0,03	0,05	0,06	0,08	0,09	0,11	0,12
200	0,04	0,06	0,08	0,1	0,12	0,14	0,16
250		0,08	0,1	0,13	0,15	0,18	0,2
300		0,09	0,12	0,15	0,18	0,21	0,25
400			0,16	0,2	0,24	0,28	0,32
500				0,25	0,3	0,35	0,4
600					0,36	0,42	0,48

$$Q \text{ (m}^3\text{/h)} = V_k \text{ (m/s)} \times A_k \text{ (m}^2\text{)} \times 3600$$

(*) Compuerta abierta

Vk (m/s)	2	4	6	8
Dpt med (Pa) (*)	20	20	29	30

Tablas de selección

Potencia sonora dB(A).

L [mm]	H [mm]	V [m/s]	Q [m ³ /h]	Lw [dB(A)]			
				100 [Pa]	250 [Pa]	500 [Pa]	1000 [Pa]
200	100	2,5	180	46	54	62	69
		5	360	51	59	67	74
		7,5	540	55	63	71	78
		10	720	58	66	74	81
	150	2,5	270	48	56	64	71
		5	540	53	61	69	76
		7,5	810	56	64	72	79
		10	1080	60	68	75	82
	200	2,5	360	49	57	65	72
		5	720	54	62	70	77
		7,5	1080	57	65	73	80
		10	1440	60	68	76	83
250	100	2,5	225	47	55	63	70
		5	450	52	60	68	75
		7,5	675	56	64	71	78
		10	900	59	67	75	82
	150	2,5	337,5	49	57	65	72
		5	675	54	62	69	76
		7,5	1012,5	57	65	73	79
		10	1350	60	68	76	83
	200	2,5	450	50	58	66	72
		5	900	55	63	70	77
		7,5	1350	58	66	73	80
		10	1800	61	69	76	83
	250	2,5	562,5	51	59	66	73
		5	1125	55	63	71	77
		7,5	1687,5	58	66	74	80
		10	2250	61	69	77	83
300	200	2,5	540	51	59	66	73
		5	1080	55	63	71	77
		7,5	1620	58	66	73	80
		10	2160	61	69	77	83
	250	2,5	675	51	59	67	73
		5	1350	56	63	71	78
		7,5	2025	58	66	74	80
		10	2700	61	69	77	83
	300	2,5	810	52	59	67	74
		5	1620	56	64	71	78
		7,5	2430	59	66	74	80
		10	3240	62	69	77	83

Tablas de selección

Potencia sonora dB(A).

L [mm]	H [mm]	V [m/s]	Q [m ³ /h]	Lw [dB(A)]			
				100 [Pa]	250 [Pa]	500 [Pa]	1000 [Pa]
400	200	2,5	720	51	59	67	73
		5	1440	56	63	71	78
		7,5	2160	58	66	74	80
		10	2880	61	69	77	83
	300	2,5	1080	52	60	67	74
		5	2160	56	64	71	78
		7,5	3240	59	66	74	80
		10	4320	62	69	77	83
	400	2,5	1440	54	62	69	76
		5	2880	58	66	73	80
		7,5	4320	61	68	75	82
		10	5760	63	71	78	85
500	250	2,5	1125	51	59	67	73
		5	2250	56	63	71	78
		7,5	3375	58	66	74	80
		10	4500	61	69	77	83
	300	2,5	1350	52	60	67	74
		5	2700	56	64	71	78
		7,5	4050	59	66	74	80
		10	5400	62	69	77	83
	400	2,5	1800	54	61	69	75
		5	3600	58	65	73	79
		7,5	5400	60	68	75	82
		10	7200	63	70	78	84
	500	2,5	2250	54	61	68	75
		5	4500	57	65	72	78
		7,5	6750	60	67	74	81
		10	9000	62	70	77	83
600	200	2,5	1080	52	60	67	74
		5	2160	56	64	71	78
		7,5	3240	59	66	74	80
		10	4320	62	69	77	83
	250	2,5	1350	52	60	67	74
		5	2700	56	64	71	78
		7,5	4050	59	66	74	80
		10	5400	61	69	76	83
	300	2,5	1620	52	60	67	74
		5	3240	56	64	71	78
		7,5	4860	59	66	74	80
		10	6480	61	69	76	83

Tablas de selección

Potencia sonora dB(A).

L [mm]	H [mm]	V [m/s]	Q [m ³ /h]	Lw [dB(A)]			
				100 [Pa]	250 [Pa]	500 [Pa]	1000 [Pa]
600	400	2,5	2160	54	61	69	75
		5	4320	57	65	72	79
		7,5	6480	60	67	74	81
		10	8640	62	70	77	83
	450	2,5	2430	54	61	68	75
		5	4860	57	65	72	78
		7,5	7290	59	67	74	81
		10	9720	62	69	77	83
	500	2,5	2700	53	60	68	74
		5	5400	57	64	71	78
		7,5	8100	59	67	74	80
		10	10800	62	69	76	83
	550	2,5	2970	53	61	68	74
		5	5940	57	64	71	78
		7,5	8910	59	66	73	80
		10	11880	61	69	76	82
	600	2,5	3240	53	60	68	74
		5	6480	56	64	71	77
		7,5	9720	59	66	73	80
		10	12960	61	68	75	82
700	400	2,5	2520	53	61	68	75
		5	5040	57	64	72	78
		7,5	7560	59	67	74	80
		10	10080	62	69	79	83
	500	2,5	3150	53	60	68	74
		5	6300	56	64	71	77
		7,5	9450	59	66	73	80
		10	12600	61	68	76	82
	600	2,5	3780	53	60	67	73
		5	7560	56	63	70	77
		7,5	11340	58	65	72	79
		10	15120	60	68	75	81
	700	2,5	4410	52	59	67	73
		5	8820	55	63	70	76
		7,5	13230	57	65	72	78
		10	17640	60	67	74	80

Tablas de selección

Potencia sonora dB(A).

L [mm]	H [mm]	V [m/s]	Q [m ³ /h]	Lw [dB(A)]			
				100 [Pa]	250 [Pa]	500 [Pa]	1000 [Pa]
800	500	2,5	3600	53	60	67	74
		5	7200	56	63	71	77
		7,5	10800	58	66	73	79
		10	14400	60	68	75	81
	600	2,5	4320	52	60	67	73
		5	8640	55	63	70	76
		7,5	12960	57	65	72	78
		10	17280	60	67	74	81
	800	2,5	5760	51	58	65	72
		5	11520	54	61	69	75
		7,5	17280	56	63	71	77
		10	23040	58	66	73	79
1000	600	2,5	5400	51	59	66	72
		5	10800	54	62	69	75
		7,5	16200	56	64	71	77
		10	21600	59	66	73	79
	800	2,5	7200	50	57	64	71
		5	14400	53	60	67	74
		7,5	21600	55	62	69	76
		10	28800	57	64	71	78
	1000	2,5	9000	49	56	63	70
		5	18000	52	59	66	72
		7,5	27000	54	61	68	74
		10	36000	56	63	70	76

Tablas de selección

Atenuación sonora en dB/Oct. (VDI 2081).

Hz	63	125	250	500	1000	2000	4000	8000
Duct	0	0	1	2	3	3	3	3
Room	5	5	5	5	5	5	5	5
Terminal reflexion	10	5	2	0	0	0	0	0

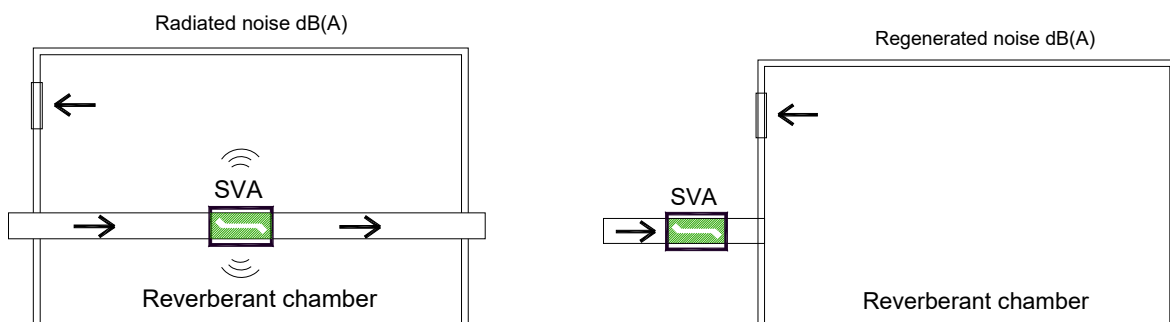

CRITERIOS PARA FIJAR V_{min} y V_{max} .

Las compuertas **SVA-C** regularan la aportación del caudal de aire básicamente para conseguir dos Fines, mantener la temperatura de consigna y una buena calidad de aire interior.

V_{min} el criterio mas común para fijar el caudal mínimo, es la calidad de aire requerido en la zona a controlar.

V_{max} el criterio mas común para fijar el caudal de aire máximo será el de la potencia térmica máxima a vencer que generalmente es la de refrigeración.

CONEXIONES DE COMPUERTAS.

Hay tres configuraciones básicas de conexión para realizar el control. Control en la impulsión y retorno con conexión paralela , control en la impulsión i retorno conexión Máster -Slave y solo control en la impulsión. El control en la impulsión i retorno permite mantener el mismo caudal de impulsión y retorno o mantener una determinada presión o sobrepresión en la zona.

CONEXIÓN IMPULSIÓN RETORNO EN PARALELO.

En el control en paralelo, tanto el controlador de impulsión como el de retorno reciben la señal de control directamente del regulador.

Los caudales se podrán fijar de forma independiente entre la impulsión y el retorno.

Este sistema de conexión se utilizara:

- En instalaciones donde la compuertas de impulsión y retorno son de dimensiones diferentes o se requiere diferentes caudales mínimos y máximos entre ellas.
- Sistemas con varias unidades de impulsión y retorno.
- Se recomiendan las instalaciones con conexión en paralelo ya que es más sencillo su diseño instalación y puesta en marcha.

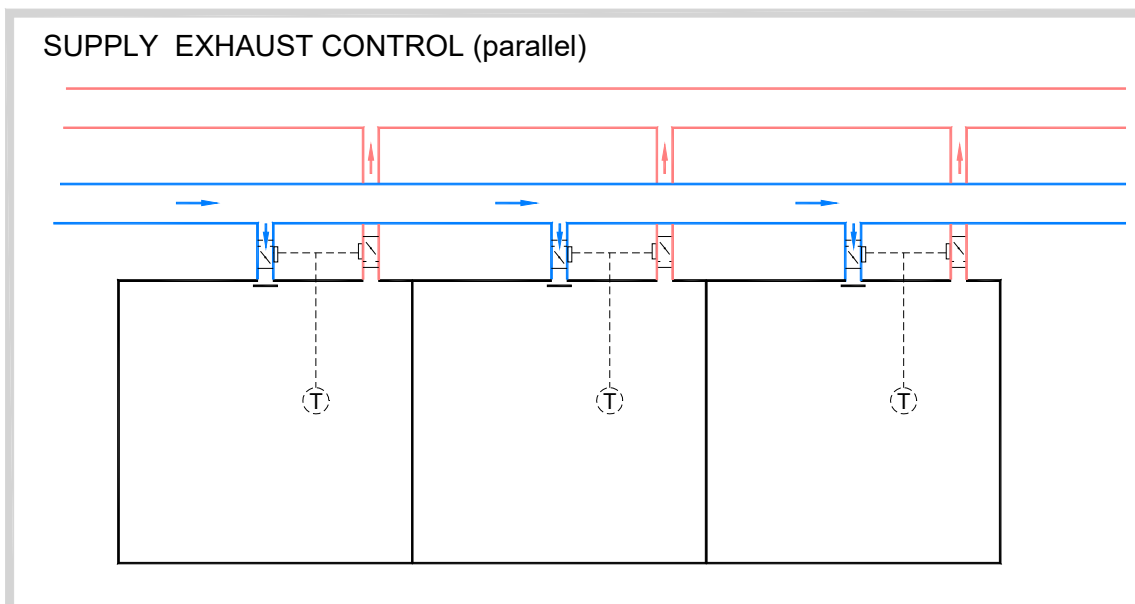
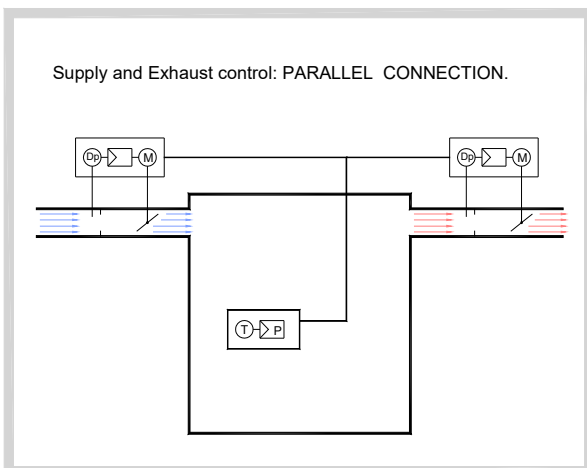

CONEXIÓN IMPULSIÓN RETORNO MÁSTER SLAVE.

En un control Master Slave el regulador envía la señal de consigna a la compuerta de impulsión y esta enviara la señal a la compuerta de retorno que actúa como slave de la de la de impulsión .

Este sistema de conexión se utiliza:

- En instalaciones donde la compuerta de retorno trabaja secuencialmente respecto a la impulsión.
- Se utiliza en zonas donde las compuertas de impulsión de aire y de retorno son de dimensiones similares.

Inconvenientes

- Cada unidad debe ser claramente etiquetada como Master o Slave y debe montarse en el lado correcto (si se intercambian las unidades deberán ser re-parametrizadas de nuevo).

La conexión Master Slave requiere una correcta identificación en todo el proceso desde el diseño, realización del pedido, instalación y puesta en marcha.

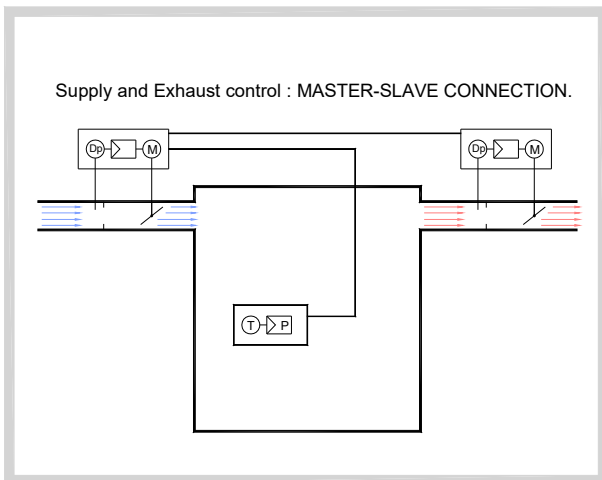

SUPPLY EXHAUST CONTROL (master / slave)

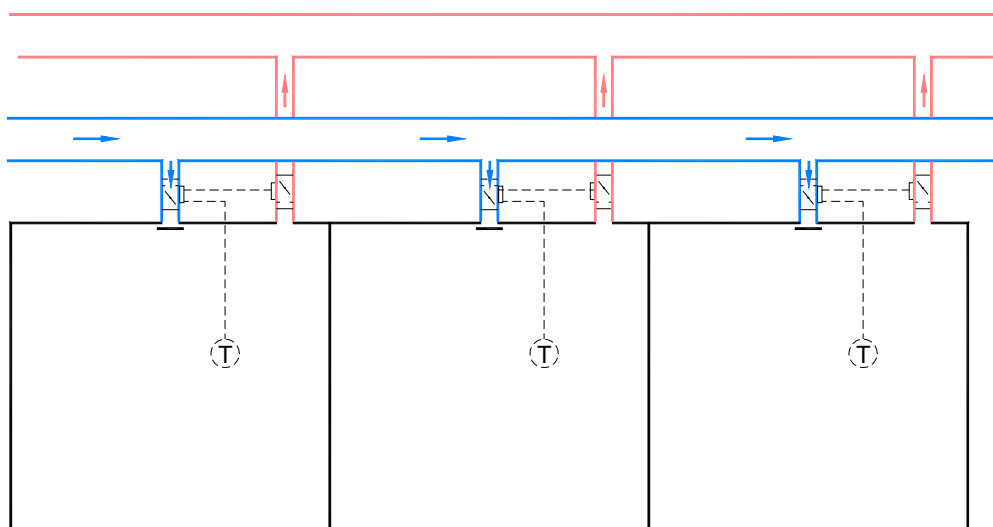

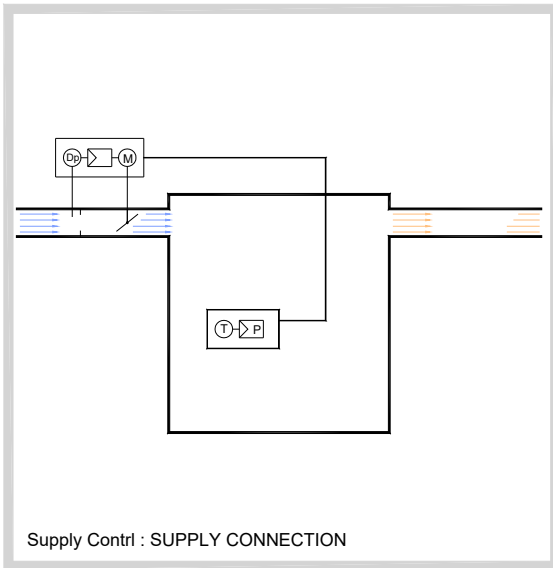

CONTROL SOLO EN LA IMPULSIÓN.

El regulador solo dará señal al controlador de impulsión.
En este tipo de instalación los retornos no se controlan.

Este sistema de conexión se utiliza:

Es un control económico al no instalar la compuerta de retorno.
Este tipo de instalación no ejerce un control del caudal de retorno por zona, esto hará que unas zonas quedarán en sobrepresión y otras en depresión.

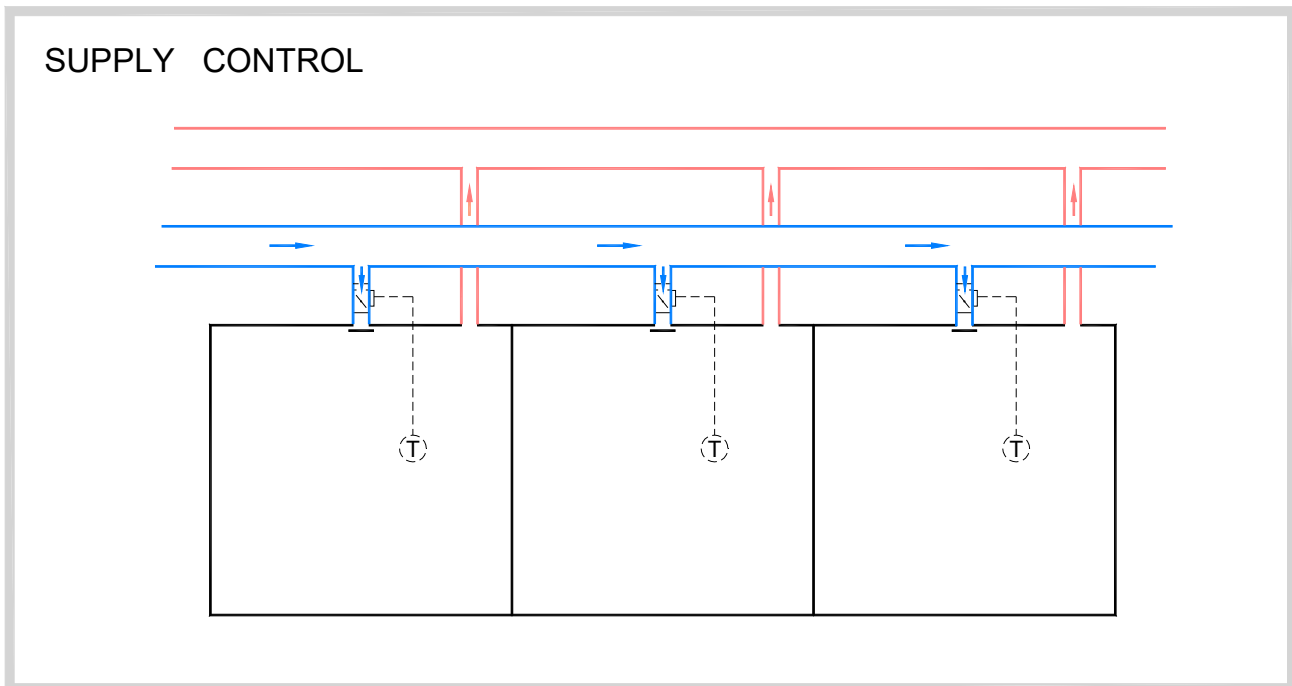

AJUSTES DEL CAUDAL DE AIRE Y CONEXIÓN STANDARD.

Las compuertas **SVA-C** se suministrarán con los caudales **Vmin** y **Vmax** preconfiguradas en fabrica siguiendo las indicaciones del cliente, estos caudales podrán ser fácilmente modificados si es necesario con las compuerta ya instaladas si se dispone de las herramientas de ajuste .

Si en el pedido no se indican los caudales que deben configurarse las compuertas se configuraran los caudales indicados según los **limite de funcionamiento**. Si solo se indica un caudal este será Considerado el Vmax y el Vmin será **limite inferior de funcionamiento**.

Las compuertas SVA-C saldrán configuradas para su conexión en paralelo, si se desea que salgan configuradas como máster Slave deberá indicarlo el cliente.

PRECAUCIONES.

Para eludir la contaminación de la cruz de medición se requiere que el aire sea limpio, se aconseja que en instalaciones donde el aire sea sucio se realice un filtrado.(las compuertas SVA-C están especialmente pensadas para instalaciones de climatización).

Deberá prevenirse toda obstrucción entre la cruz de medición y el servomotor . Una de estas obstrucciones puede ser debido a la aparición de condensación en el interior de estos manguitos cuando el gradiente del aire de impulsión i el aire en contacto con el manguito sea elevado, esta condensación podrá llegar a dañar el servo, para eludir esta condensación se debe aislar los manguitos.

INSTRUCCIONES DE MONTAJE.

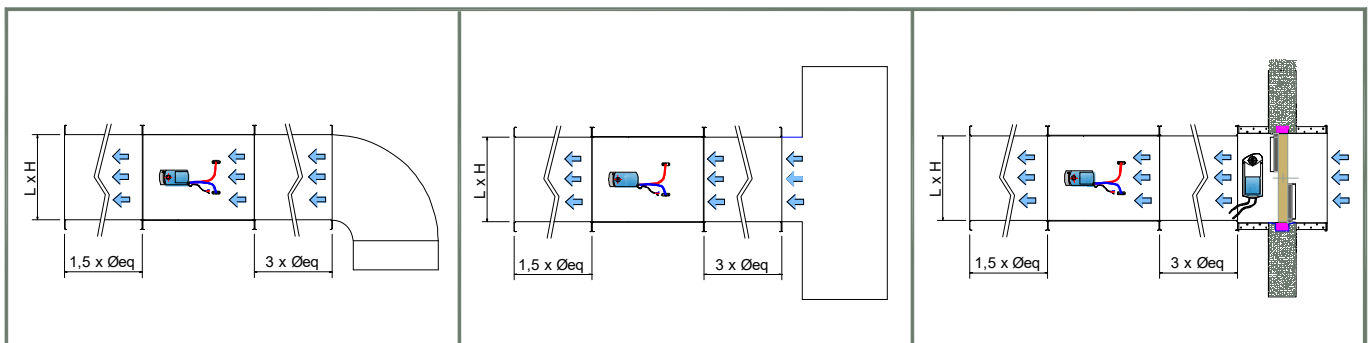

$$\varnothing \text{ eq} = \frac{2 \times H \times L}{H + L}$$

PARTICULARIDADES

En las instalaciones de VAV hay que garantizar el suministro de los caudales en que han sido Proyectadas , si no se garantizan los caudales mínimos las compuertas no llegaran nunca a ejercer una regulación sobre el caudal y se posicionaran 100% abiertas.

CONTACTOS FORZADOS O IMPERATIVOS

Los servomotores disponen de contactos forzados que permiten el cierre total de las compuertas o la apertura total, independientemente de la señal 0-10 v del regulador.

Dichos contactos permiten el cierre total de la compuerta si no hay ocupación o la apertura total para llegar de forma mas rápida al set point o forzar una ventilación máxima .

VAV variable airflow - Room Temperature control with Manual changeover. Air supply control.

Wiring diagram SIEMENS



SVA-R / GDB181.1E/3



RDG 400

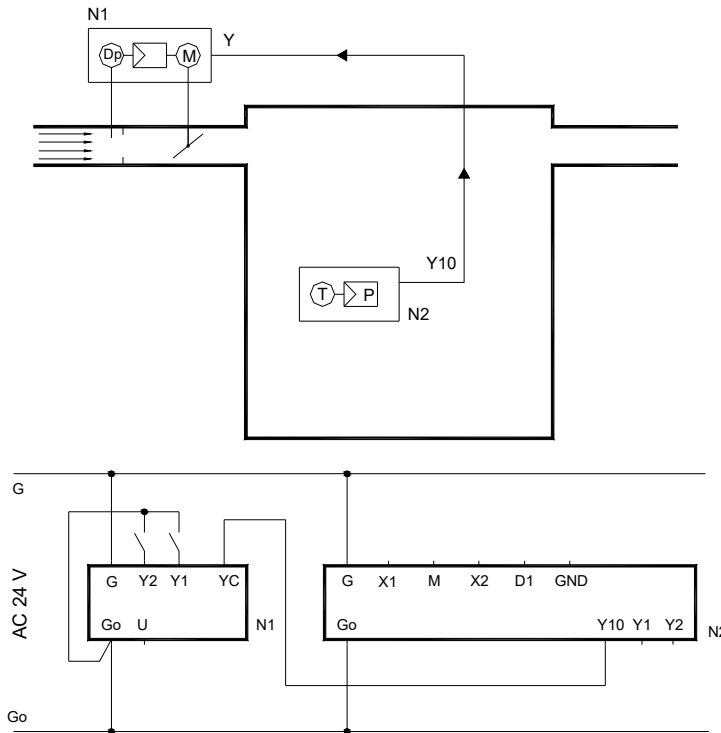

N1 SVA -C / GDB181.1E/3

G	Red (RD)	Live AC 24 V
G0	Black (BK)	System neutral AC 24 V
Y1	Violet (VT)	Position Signal (factory setting)
Y2	Orange (OG)	Position signal (factory setting)
YC	Grey (GY)	Air volume position signal DC 0.....10v
U	Pink (PK)	Air volume measuring signal DC 0....10v

N2 RDG 400

G, G0	Operating voltage AC 24 V
Y10/G0	Control output for DC 0 ... 0 V actuator
Y1 /G, Y2/G	Control output.
X1, X2	Multifunctional input for temperature sensor
X1	external room temperature sensor.
X2	Switch for automatic heating/cooling changeover
M	Measuring neutral for sensor and switch
D1, GND	Multifunctional input for potential-free switch.

GDB181.1E/3 OVERRIDE CONTROL.

Modular control Vmin and Vmax

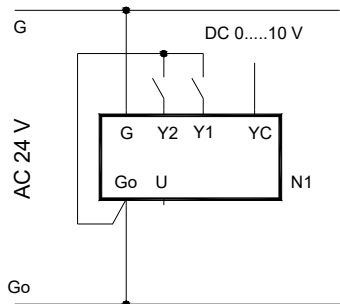

Fully closed

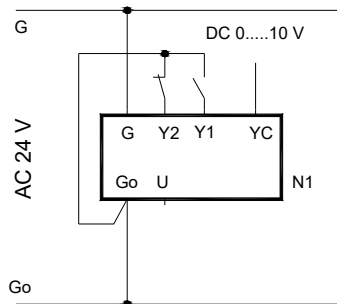

Fully open

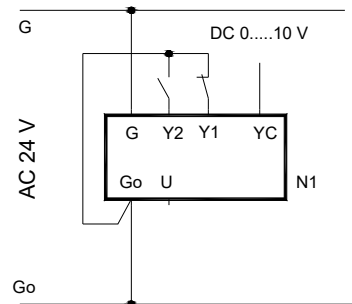

RDG 400

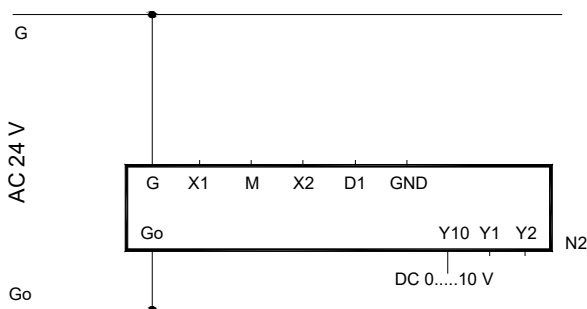

N2 RDG 400 Room temperature controller Commissioning

DIP Swiches



Parameters

- P010 = only heating
- 1 = only Cooling (Default)
- 2 = Manual changeover
- P02-P14Default values

VAV variable airflow - Room temperature control with remote changeover. Air supply control.

Wiring diagram **SIEMENS**



SVA-R / GDB181.1E/3/



RDG 400

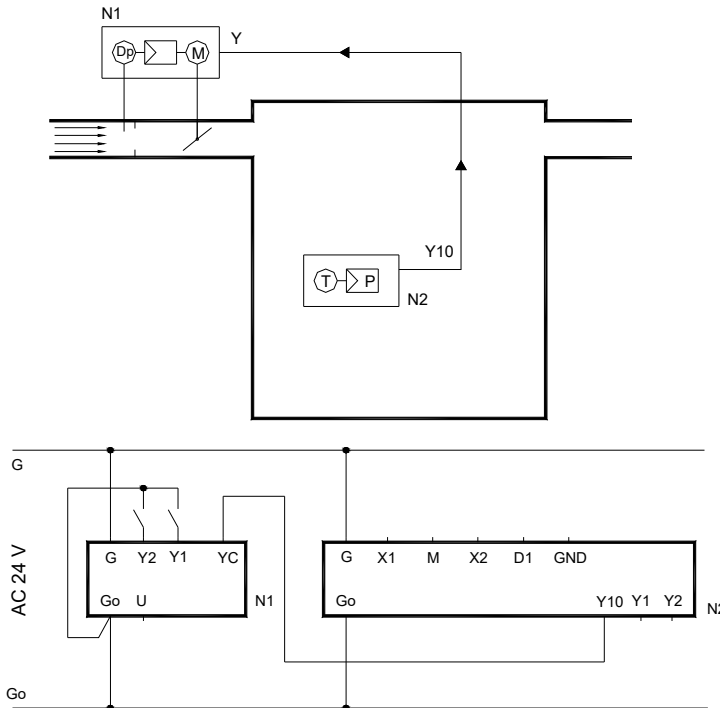

N1 SVA-C / GDB181.1E/3

- G Red (RD) Live AC 24 V
- G0 Black (BK) System neutral AC 24 V
- Y1 Violet (VT) Position Signal (factory setting)
- Y2 Orange (OG) Position signal (factory setting)
- YC Grey (GY) Air volume position signal DC 0....10v
- U Pink (PK) Air volume measuring signal DC 0....10v

N2 RDG 400

- G, G0 Operating voltage AC 24 V
- Y10/G0 Control output for DC 0 ... 0 V actuator
- Y1 /G, Y2/G Control output.
- X1, X2 Multifunctional input for temperature sensor
 - X1 external room temperature sensor.
 - X2 Switch for automatic heating/cooling changeover
- M Measuring neutral for sensor and switch
- D1, GND Multifunctional input for potential-free switch.

GDB181.1E/3 OVERRIDE CONTROL.

Modular control Vmin and Vmax

Fully closed

Fully open

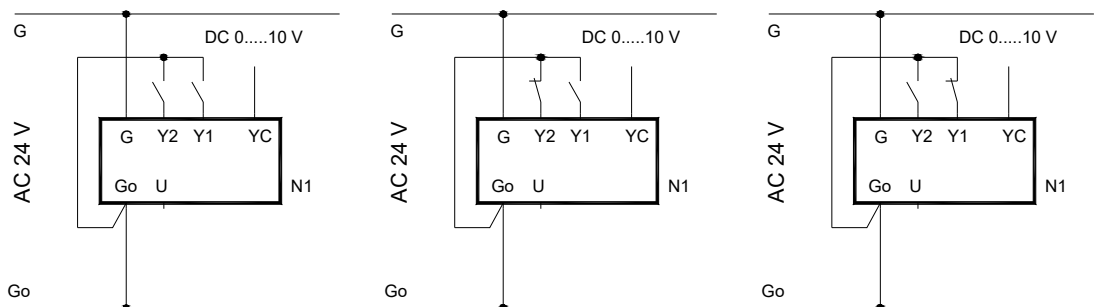

RDG 400

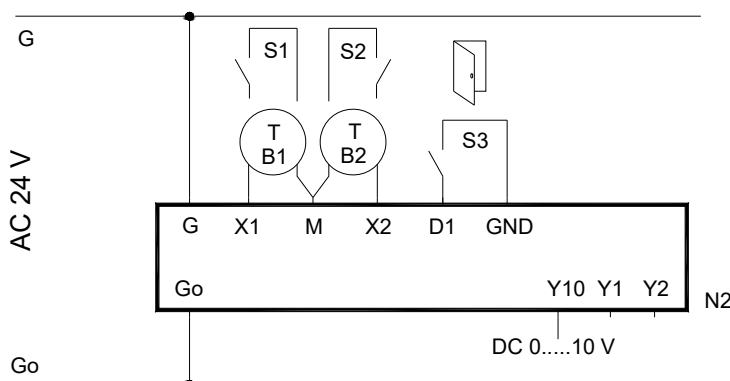

N2 RDG 400 Room Temperature controller

Commissioning
DIP Switches

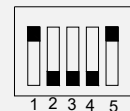

- Parameters
- P01..... 3= automatic heating / cooling changeover
 - P02-P14.....Default values.

TB2 - Automatic heating / cooling changeover.

Optional - Switch or Sensor **QAH11.1**
QAH1.1 install in the supply air.

S3 - Optional Switch (keycard, window contacto, etc)

VAV variable airflow - Room temperature control with remote changeover. Air supply and exhaust control with parallel connection.

Wiring diagram **SIEMENS**



SVA-R/GDB181.1E/3/



RDG 400

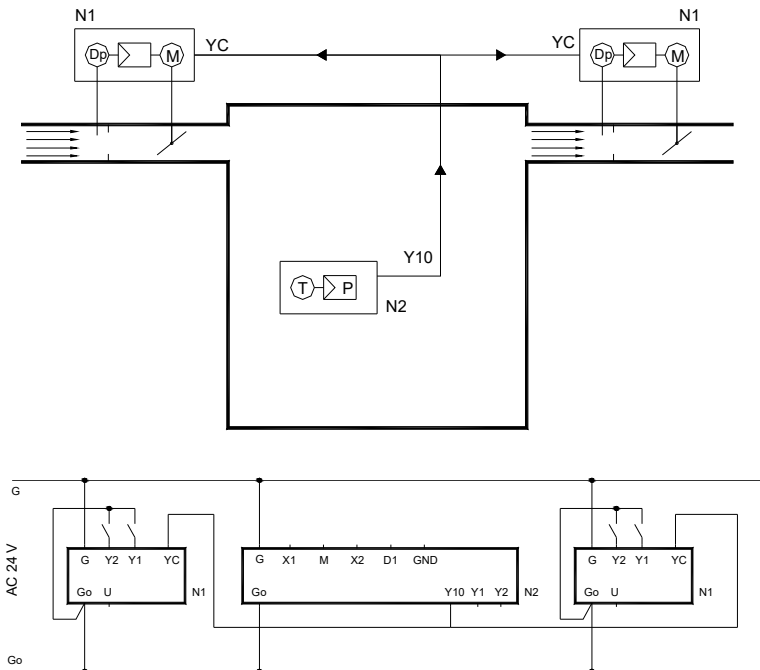

N1 SVA -C / GDB181.1E/3

- G Red (RD) Live AC 24 V
- G0 Black (BK) System neutral AC 24 V
- Y1 Violet (VT) Position Signal (factory setting)
- Y2 Orange (OG) Position signal (factory setting)
- YC Grey (GY) Air volume position signal DC 0.....10v
- U Pink (PK) Air volume measuring signal DC 0.....10v

N2 RDG 400

- G, G0 Operating voltage AC 24 V
- Y10/G0 Control output for DC 0 ... 0 V actuator
- Y1 /G, Y2/G Control output.
- X1, X2 Multifunctional input for temperature sensor
 - X1 external room temperature sensor.
 - X2 Switch for automatic heating/cooling changeover
- M Measuring neutral for sensor and switch
- D1, GND Multifunctional input for potential-free switch.

GDB181.1E/3 OVERRIDE CONTROL (must be wired to both actuators).

Modular control V_{min} and V_{max}

Fully closed

Fully open

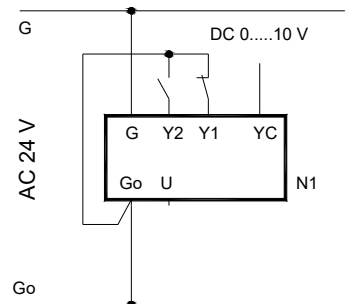
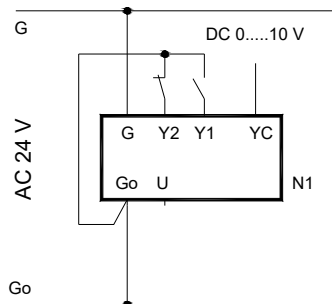
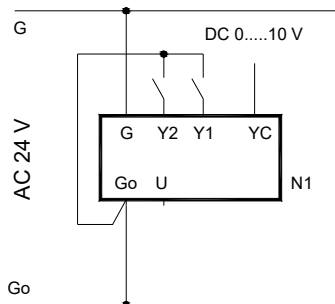

RDG 400

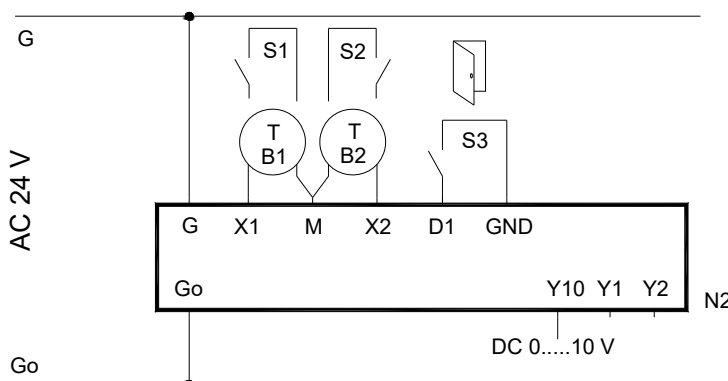

N2 RDG 400 Room temperature controller.

Commissioning
DIP Switches

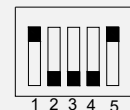

Parameters

P01..... 3= automatic heating / cooling changeover
P02-P14.....Default values.

TB2 - Automatic heating / cooling changeover.

Optional - Switch or Sensor **QAH1.1**
QAH1.1 install in the supply air.

S3 - Optional Switch (keycard, window contacto, etc)

VAV variable airflow - RoomTemperature control with remote changeover. Air supply and exhaust control with Master-Slave connection.

Wiring diagram **SIEMENS**



SVA-R /GDB181.1E/3/



RDG 400

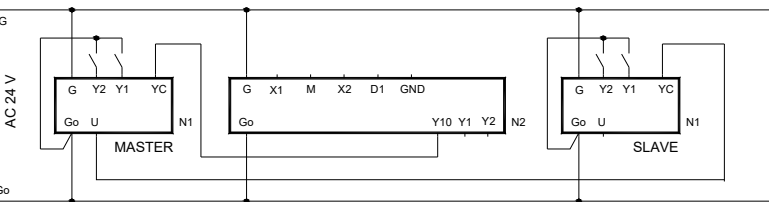
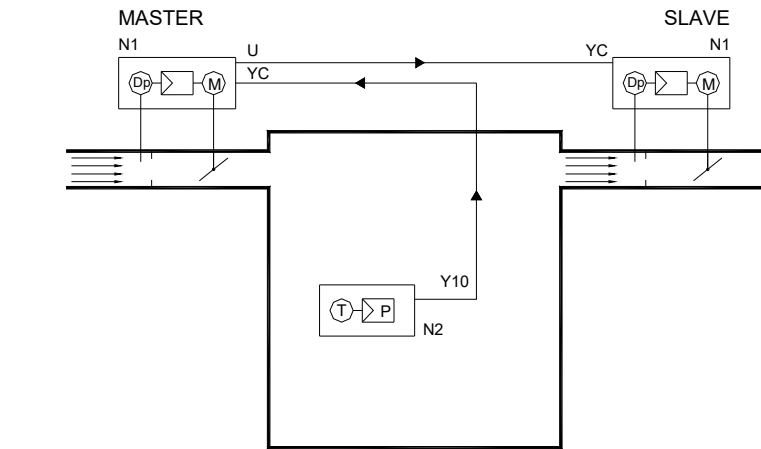

N1 SVA -C / GDB181.1E/3

- G Red (RD) Live AC 24 V
- G0 Black (BK) System neutral AC 24 V
- Y1 Violet (VT) Position Signal (factory setting)
- Y2 Orange (OG) Position signal (factory setting)
- YC Grey (GY) Air volume position signal DC 0.....10v
- U Pink (PK) Air volume measuring signal DC 0....10v

N2 RDG 400

- G, G0 Operating voltage AC 24 V
- Y10/G0 Control output for DC 0 ... 0 V actuator
- Y1 /G, Y2/G Control output.
- X1, X2 Multifunctional input for temperature sensor
 - X1 external room temperature sensor.
 - X2 Switch for automatic heating/cooling changeover
- M Measuring neutral for sensor and switch
- D1, GND Multifunctional input for potential-free switch.

GDB181.1E/3 OVERRIDE CONTROL (must be only wired to the MASTER).

Modular control V_{min} and V_{max}

Fully closed

Fully open

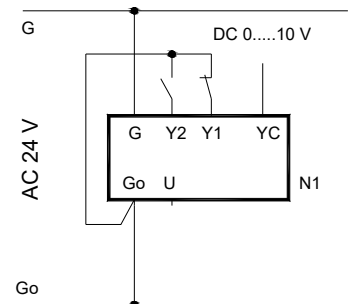
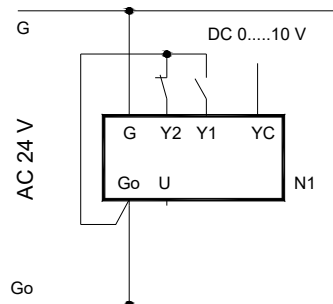
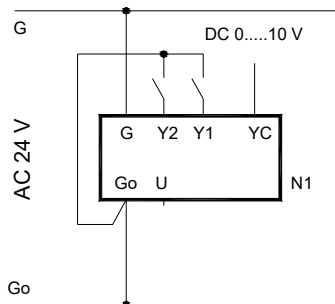

RDG 400

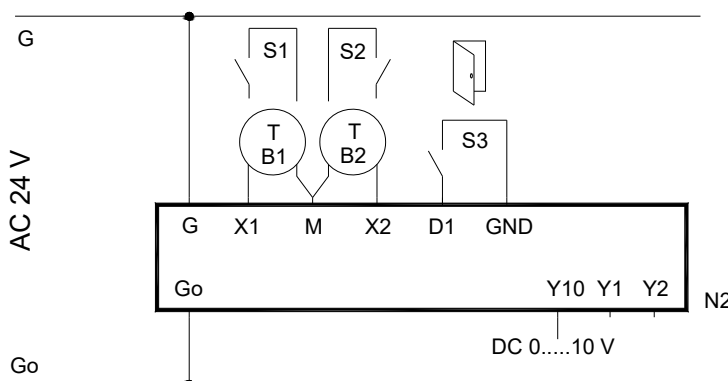

N2 RDG 400 Room Temperature controller

Commissioning

DIP Switches



Parameters

P01..... 3= automatic heating / cooling changeover

P02-P14.....Default values.

TB2 - Automatic heating / cooling changeover.

Optional - Switch or Sensor **QAH11.1**

QAH11.1 install in the supply air.

S3 - Optional Switch (keycard, window contacto, etc)

VAV variable airflow - Room temperature control centralized , remote changeover.

Air supply control .

Wiring diagram **SIEMENS**



SVA-R /GDB181.1E/3/



RDG 400



RAK-TR

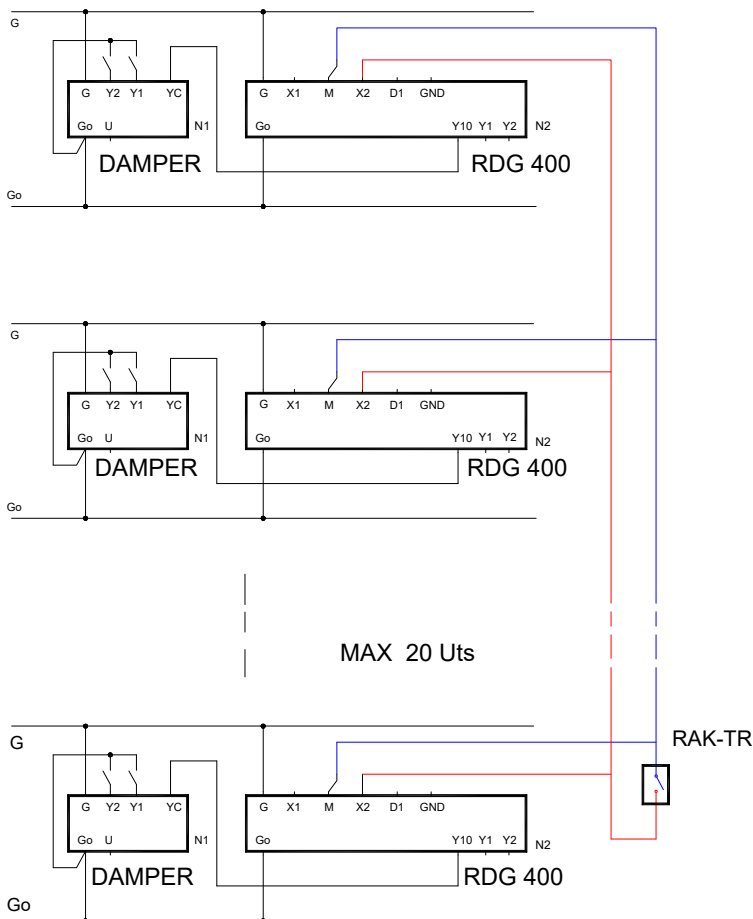
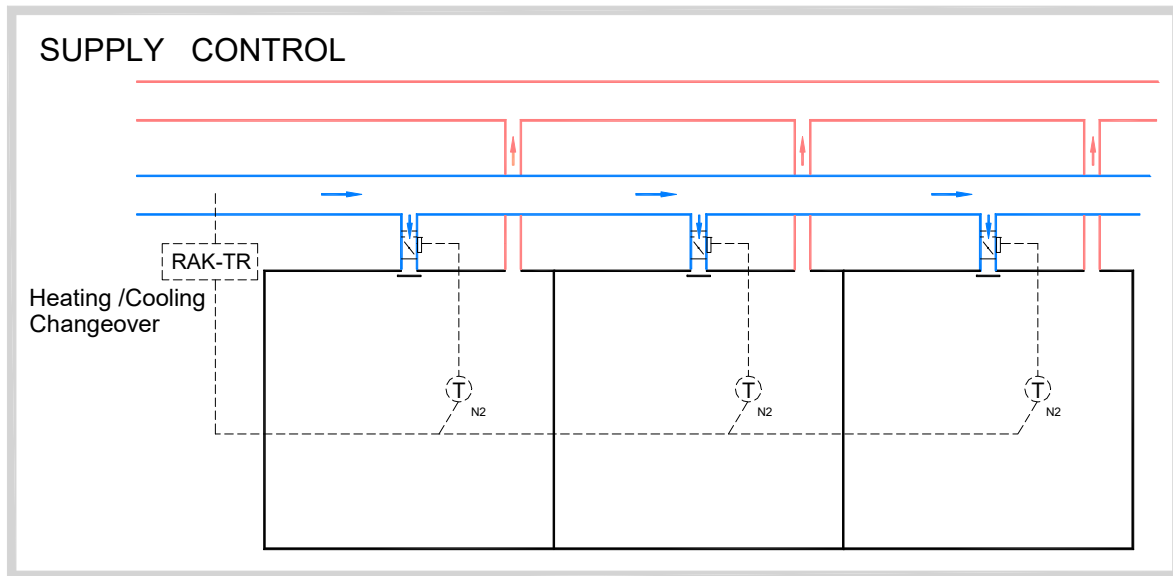

Termostato Mecánico RAK-TR
 Termostato mecánico de inmersión, escala 0° a 40° C, diferencial 2°, calefacción / refrigeración, Vaina 200x100 mm rosca 1/2'' (Seleccionar 27°C en el termostato).

CAV Constant air flow.
Air supply or exhaust control.
 Wiring diagram **SIEMENS**



SVA-R /GDB181.1E/3/

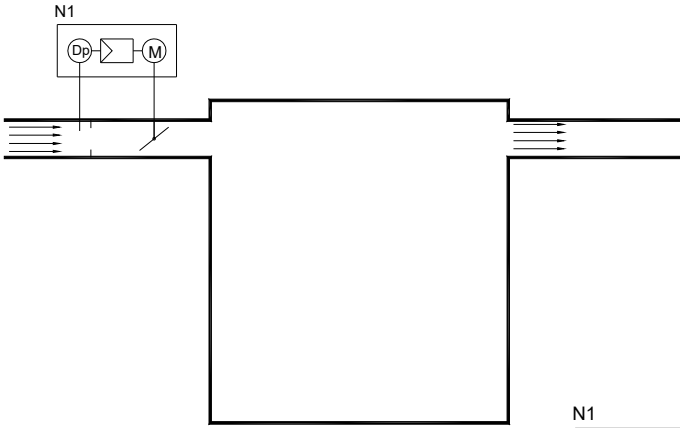

Air supply control .

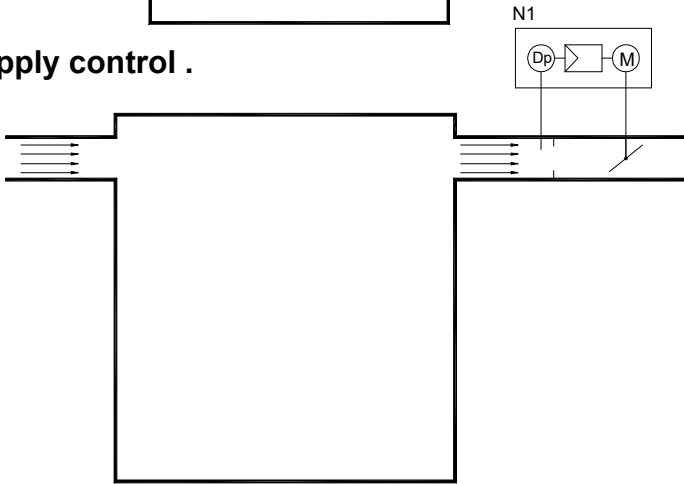

V min value

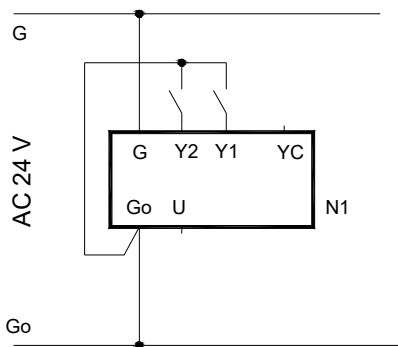

V max value

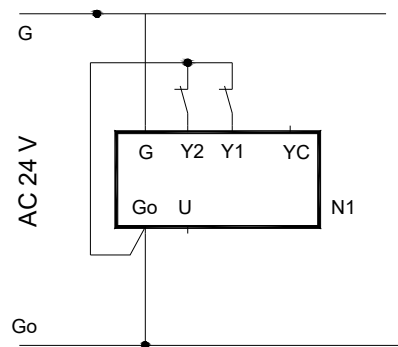

Fully closed

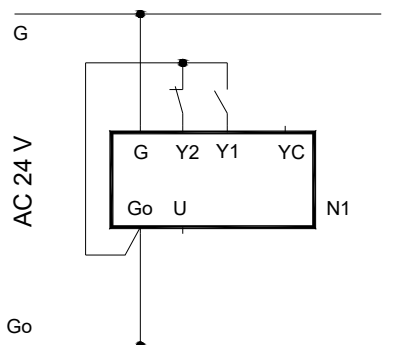

Fully open

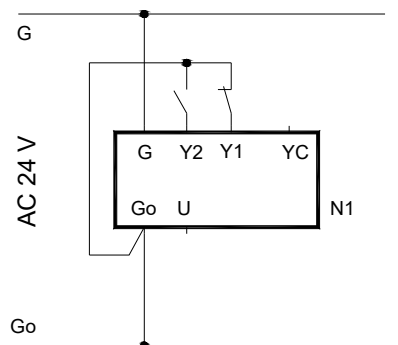

VAV variable airflow - Room CO₂ control. Supply, exhaust, supply and exhaust control.

Wiring diagram SIEMENS

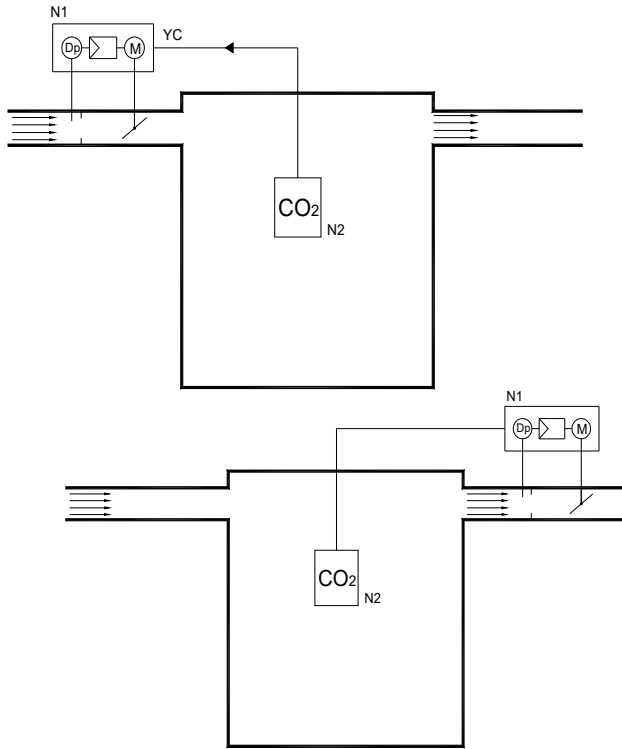

SVA-R/GDB181.1E/3/



CO2-WP

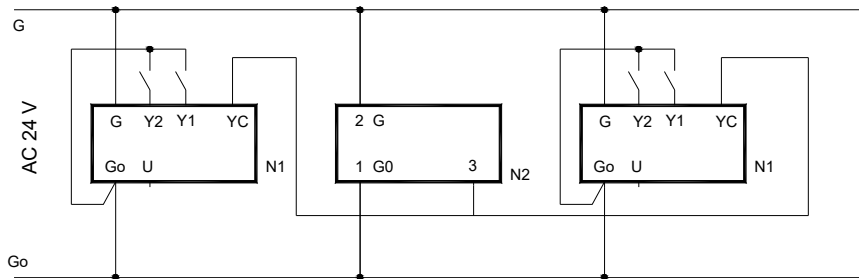
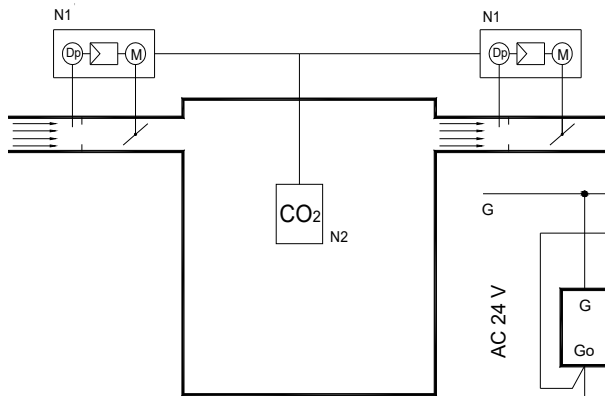
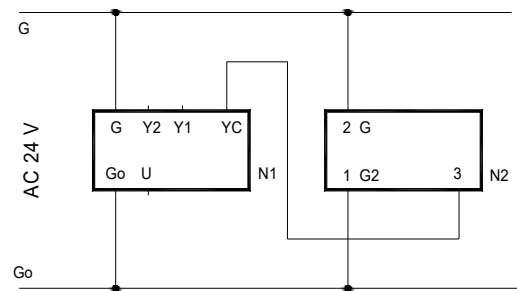

	Concentración de CO ₂ (ppm)	
	Rango	valor por defecto
IDA 1 Calidad alta	≤ 400	350
IDA 2 Calidad media	400....600	500
IDA 3 Calidad moderada	600....1.000	800
IDA 4 Calidad baja	> 1.000	1.200

350 ppm :Concentración media en aire exterior.

500 a 800 ppm :Condiciones de bienestar en los edificios.

1.500 ppm :Límite de bienestar en los edificios.

Commissioning. Jumper Position.

	J1	J2
0-10 VDC(default)	disconnected	disconnected
2-10 VDC	connected	disconnected

	J3
PID out put (default)	disconnected
Linear output	connected

	J4	J5
350 ppm	disconnected	disconnected
500 ppm	connected	disconnected
800 ppm (default)	disconnected	connected
1200 ppm	connected	connected

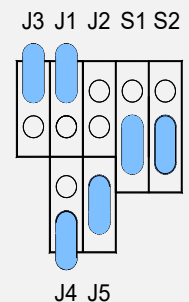

Communicative VAV Air control.

Wiring diagram **SIEMENS**

Air supply control.



N1 VAV compact air flow controller with Actuator and pressure sensor

N2 Room temperature controller with sensor

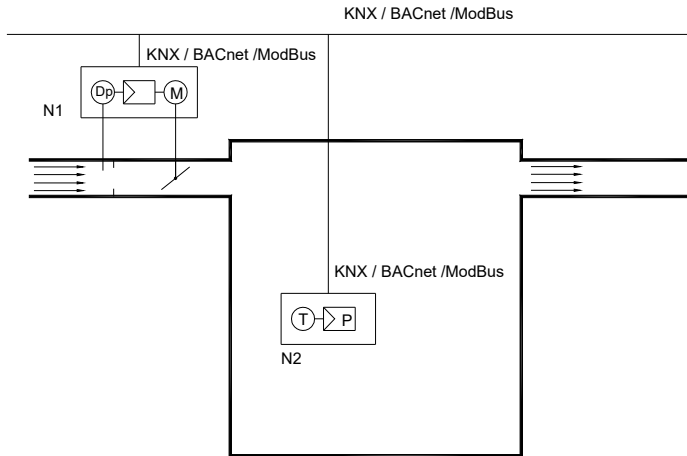

N1 SVA -C / GDB181.1E/ KN /	
1	red (RD) System voltage AC 24 V
2	black (BK) System neutral AC 24 V
6	Violet (VT) Reference
8	Grey (GY) Bus (KNX RTU)
9	Pink (PK) Bus (KNX RTU)

Air supply and exhaust control

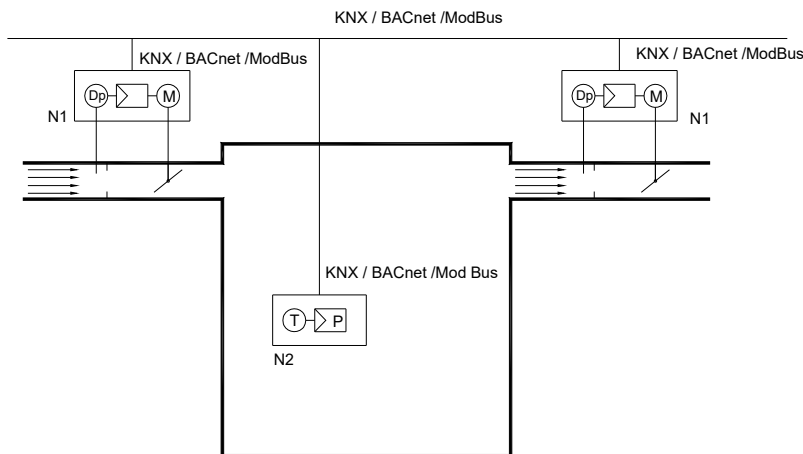

N1 SVA -C / GDB181.1E/ BA /	
1	red (RD) System voltage AC 24 V
2	black (BK) System neutral AC 24 V
6	Violet (VT) Reference
8	Grey (GY) Bus (BACnet RTU)
9	Pink (PK) Bus (BACnaet RTU)



N1 SVA -C / GDB181.1E/ MO /	
1	red (RD) System voltage AC 24 V
2	black (BK) System neutral AC 24 V
6	Violet (VT) Reference
8	Grey (GY) Bus (Modbus RTU)
9	Pink (PK) Bus (Modbus RTU)

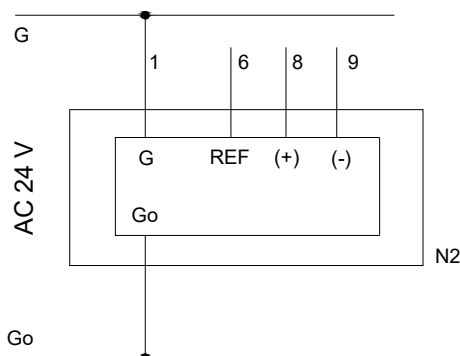

VAV variable airflow - Room Temperature control with remote changeover. Air supply Control.

Wiring diagram **BELIMO**



SVA-R/LMV-D3-MP/

CR24-B1

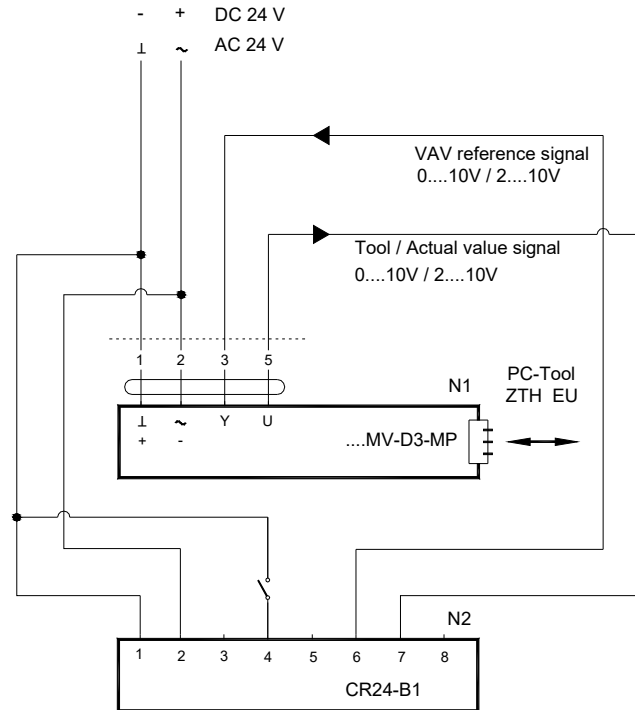
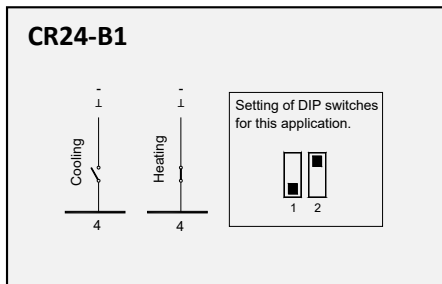
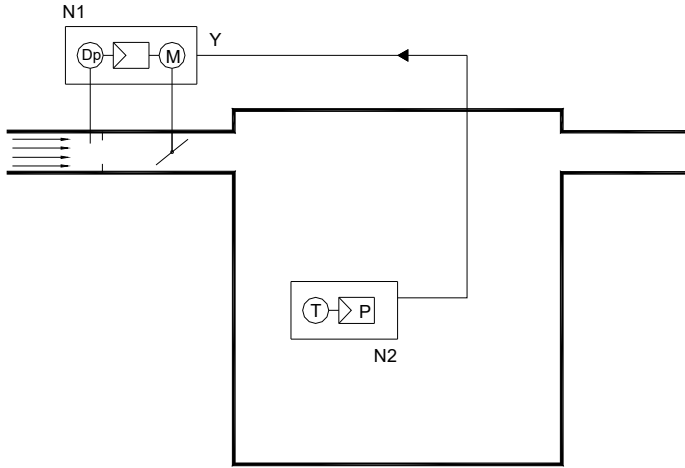

OVERRIDE CONTROL

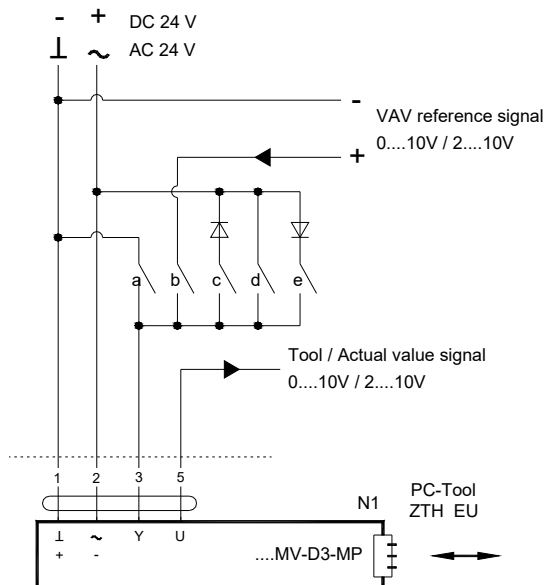

	a	b	c	d	e
Mode setting	-	0...10 V	0...10 V	0...10 V	0...10 V
	2...10 V	2...10 V	2...10 V	2...10 V	2...10 V
Signal	I -	0...10 V 2...10 V	~	~ +	~
Function	3	3	3	3	3
Damper CLOSED	CLOSED		CLOSED		
V̇ min...V̇ max		VAV			
CAV...V̇ min	ALL open - V̇ min active				
Damper OPEN					OPEN
CAV...V̇ max				V̇ max	

Note. Only one contact closed at same time.

Signals 'c' and 'e' only available with AC 24 V supply.

VAV variable airflow - Room Temperature control.
Air supply air.
Wiring diagram BELIMO



SVA-R/LMV-D3-MP/

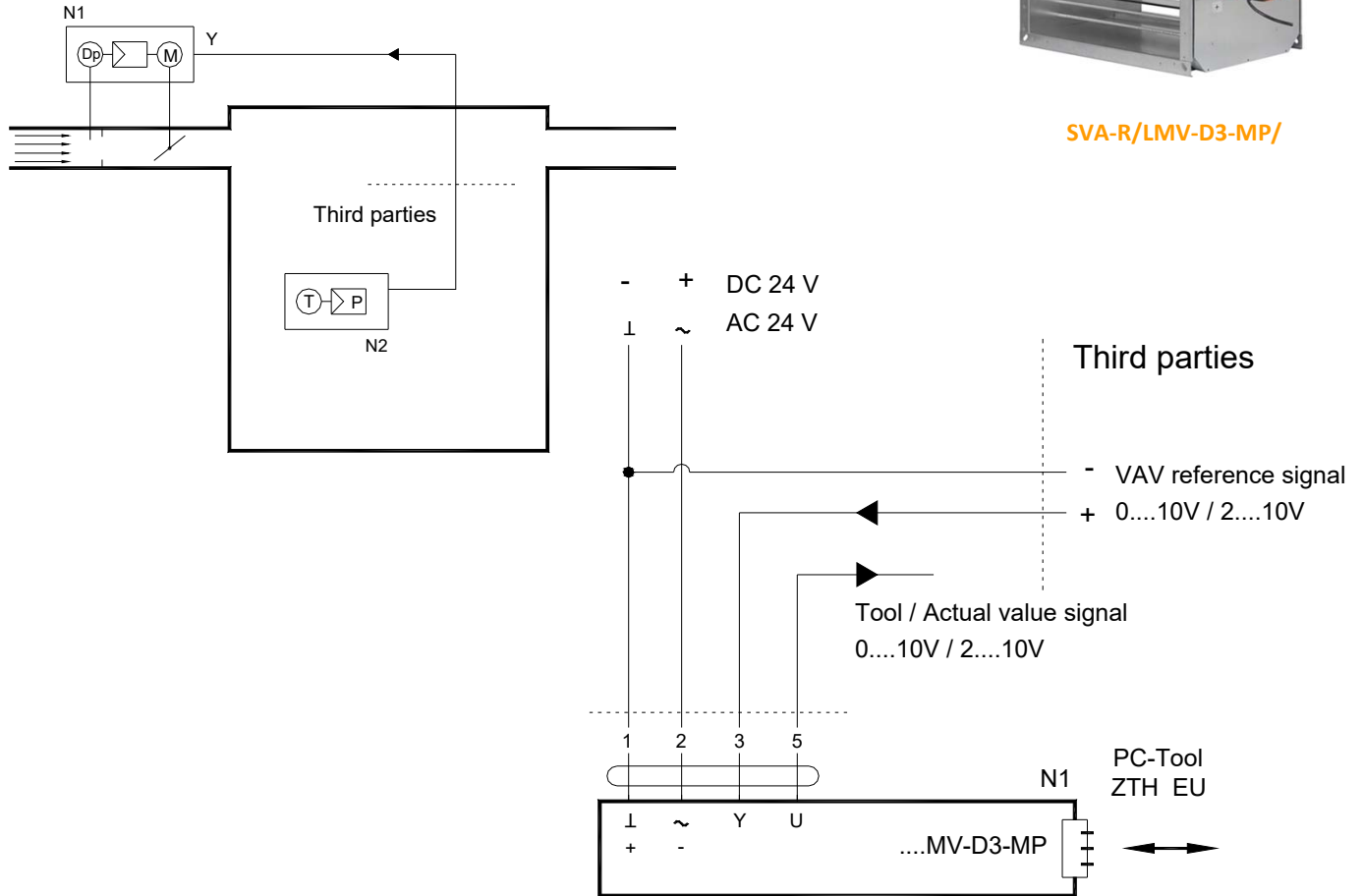

VERRIDE CONTROL

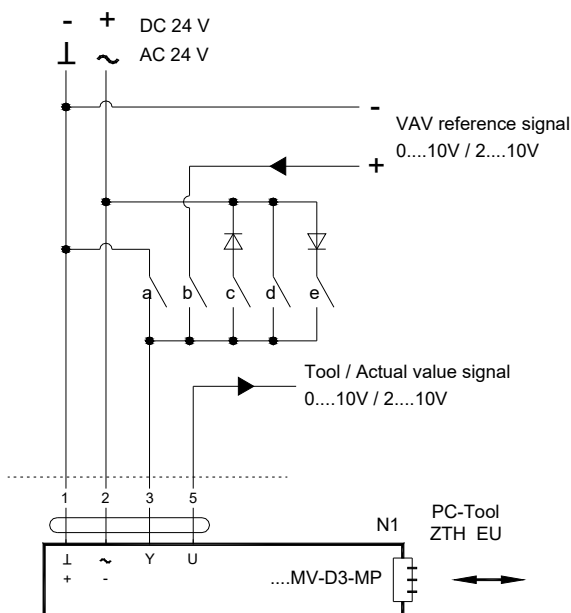

	a	b	c	d	e
Mode setting	-	0.....10 V	0.....10 V	0.....10 V	0.....10 V
	2.....10 V	2.....10 V	2.....10 V	2.....10 V	2.....10 V
Signal	⊥ -	0.....10 V 2.....10 V	~	~ +	~
Function	⊕ 3	⊕ 3	⊕ 3	⊕ 3	⊕ 3
Damper CLOSED	CLOSED		CLOSED		
\check{v} min... \check{v} max		VAV			
CAV... \check{v} min	ALL open - \check{v} min active				
Damper OPEN					OPEN
CAV... \check{v} max				\check{v} max	

Note. Only one contact closed at same time.
 Signals 'c' and 'e' only available with AC 24 V supply.

VAV variable airflow - Room temperature control. Air supply and exhaust control with Parallel connection.

Wiring diagram **BELIMO**



SVA-R/LMV-D3-MP/

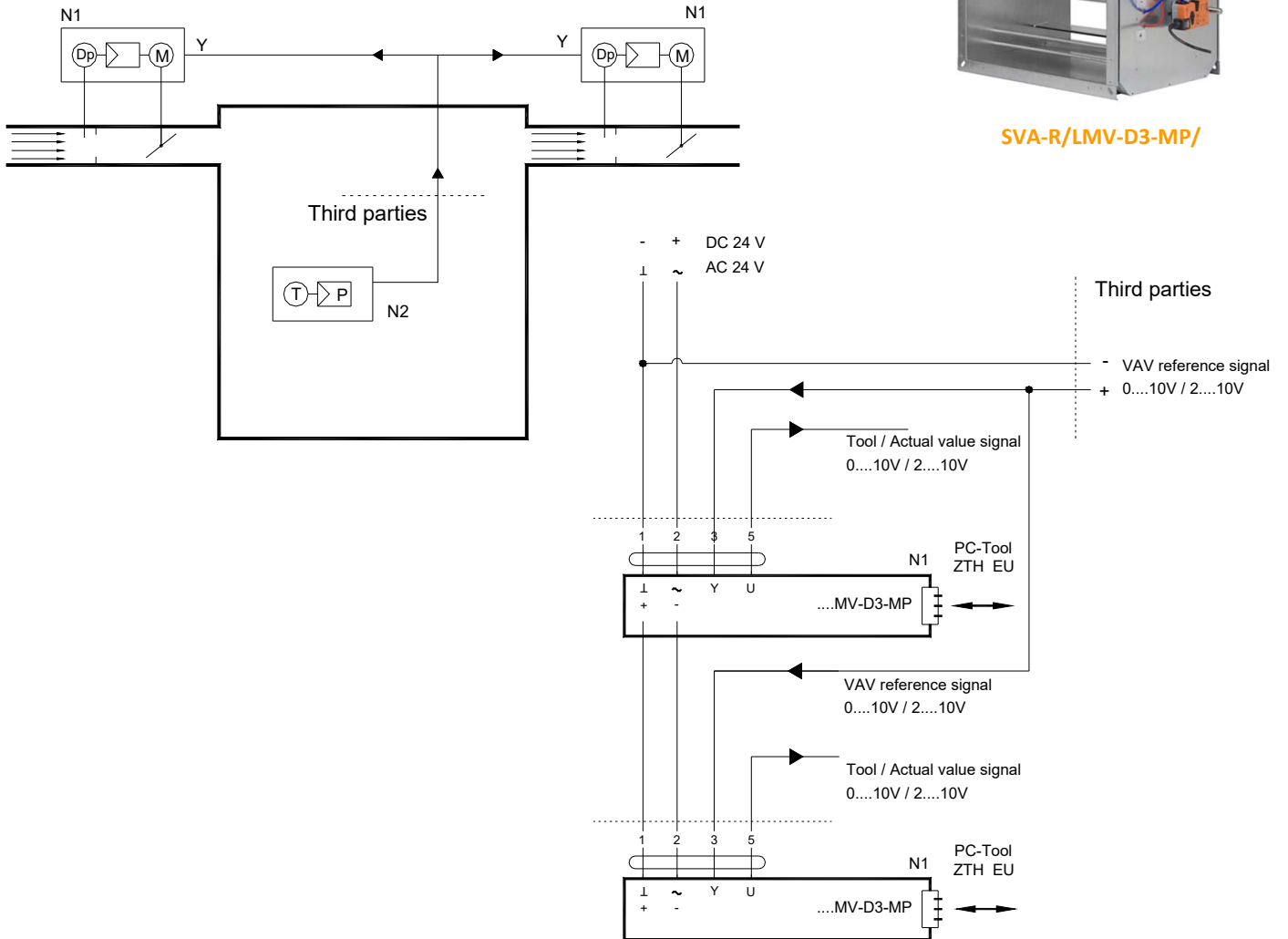

VERRIDE CONTROL (must be wired to both actuators)

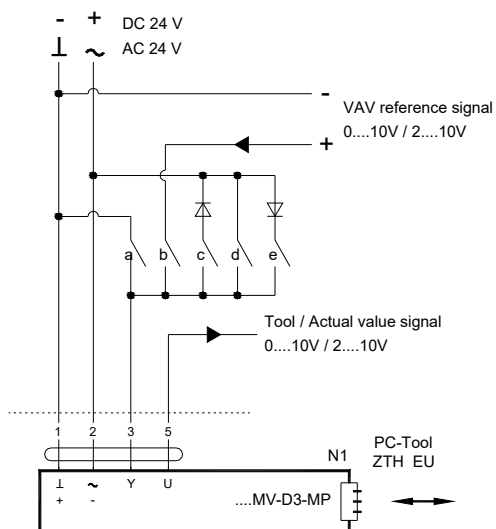

	a	b	c	d	e
Mode setting	-	0....10 V	0....10 V	0....10 V	0....10 V
	2....10 V	2....10 V	2....10 V	2....10 V	2....10 V
Signal	\perp -	0....10 V 2....10 V	\sim	\sim +	\sim
Function	\perp 3	\perp 3	\sim 3	\sim 3	\sim 3
Damper CLOSED	CLOSED		CLOSED		
\checkmark min... \checkmark max		VAV			
CAV... \checkmark min	ALL open - \checkmark min active				
Damper OPEN					OPEN
CAV... \checkmark max				\checkmark max	

Note. Only one contact closed at same time.

Signals 'c' and 'e' only available with AC 24 V supply.

VAV variable airflow – Room temperature control. Air supply and exhaust control with Master-Slave connection.

Wiring diagram **BELIMO**

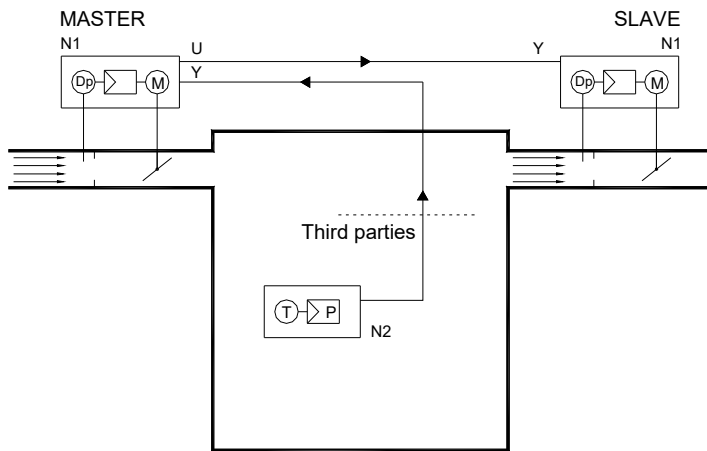

SVA-R/LMV-D3-MP/

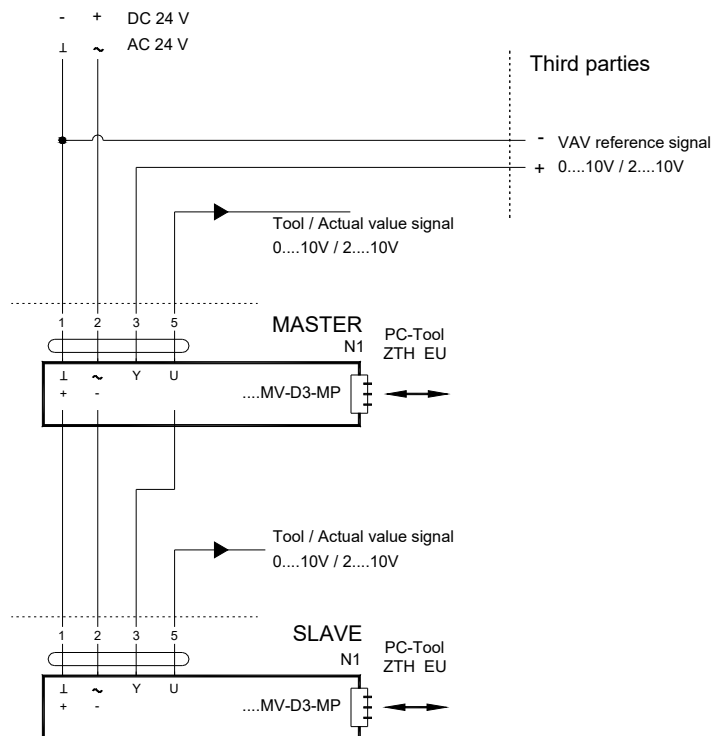

VERRIDE CONTROL (must be only wired to the MASTER)

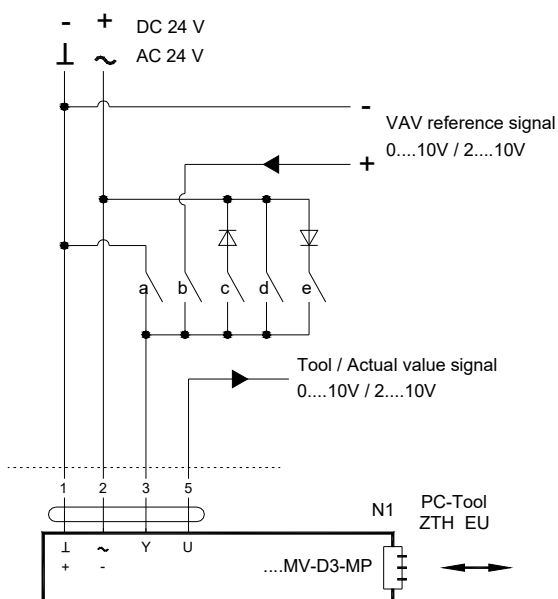

	a	b	c	d	e
Mode setting	-	0...10 V	0...10 V	0...10 V	0...10 V
	2...10 V	2...10 V	2...10 V	2...10 V	2...10 V
Signal	$\frac{\perp}{-}$	$\frac{0...10\text{ V}}{2...10\text{ V}}$	\sim	$\frac{\sim}{+}$	\sim
Function	\odot 3	\odot 3	\triangle \odot 3	\odot 3	∇ \odot 3
Damper CLOSED	CLOSED		CLOSED		
\dot{V} min... \dot{V} max		VAV			
CAV... \dot{V} min	ALL open - \dot{V} min active				
Damper OPEN					OPEN
CAV... \dot{V} max				\dot{V} max	

Note. Only one contact closed at same time.

Signals 'c' and 'e' only available with AC 24 V supply.

VAV variable airflow - Room temperature control with centralized, remote changeover Air supply control.



SVA-R/LMV-D3-MP/



CR24-B1



RAK-TR

- + DC 24 V
L ~ AC 24 V

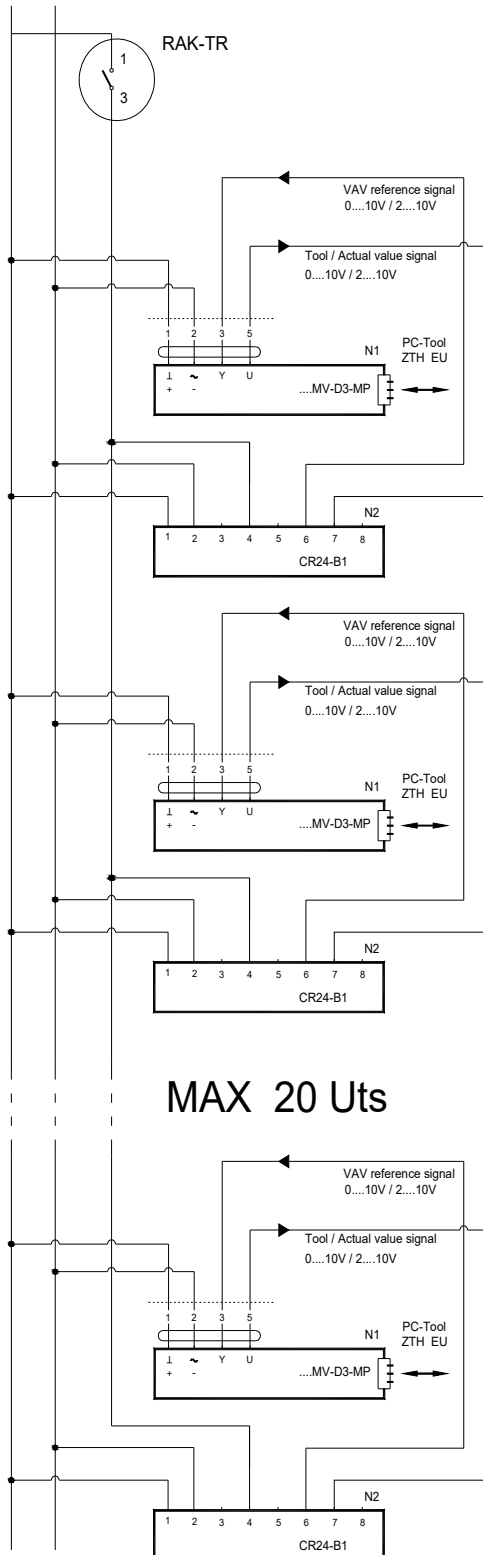

MAX 20 Uts

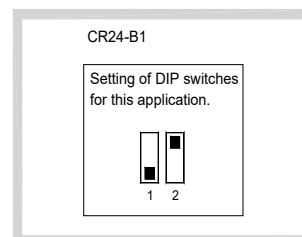
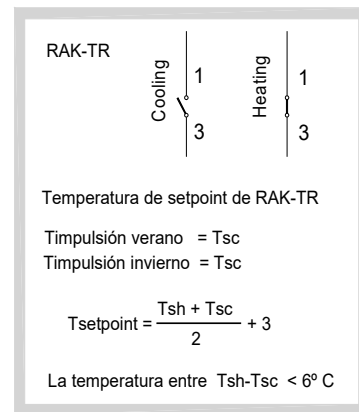
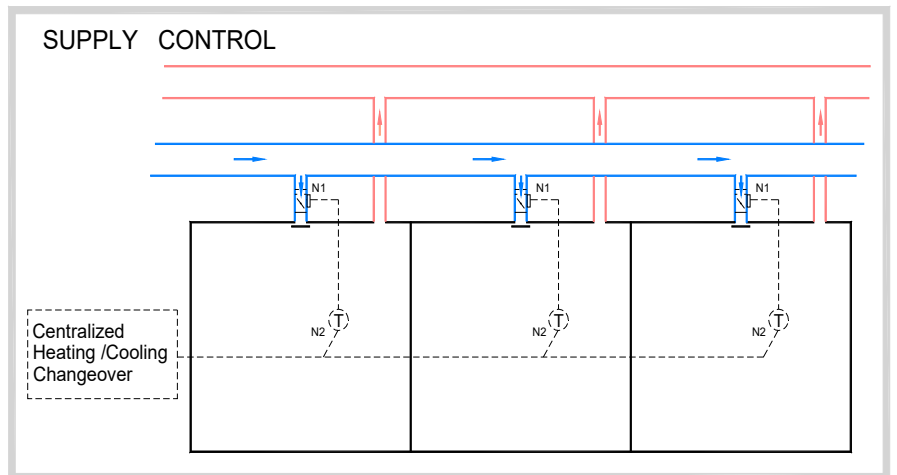

VAV variable airflow - Room CO₂ control. Supply, exhaust, supply and exhaust control.

Wiring diagram BELIMO



SVA-R/LMV-D3-MP/

CO2-WP

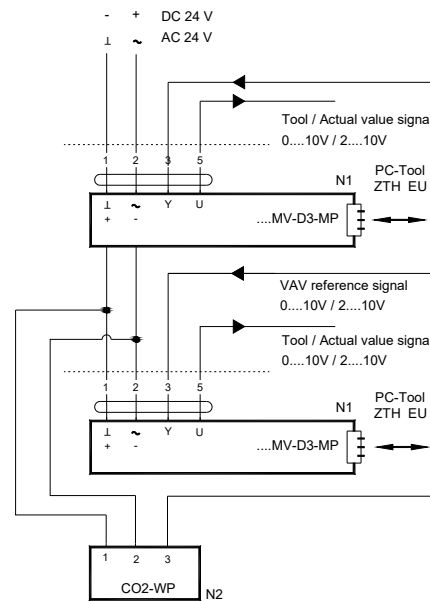
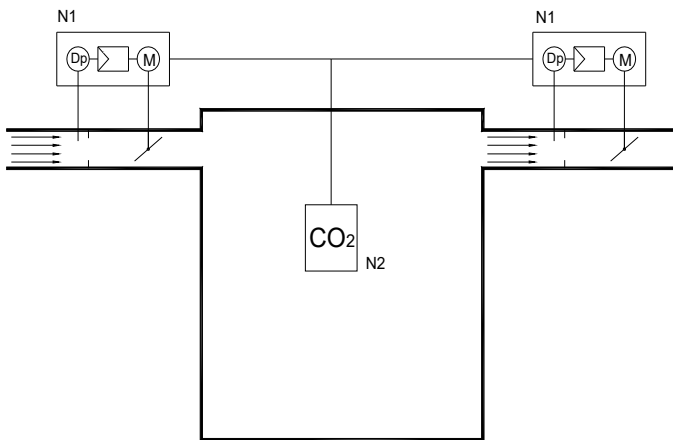
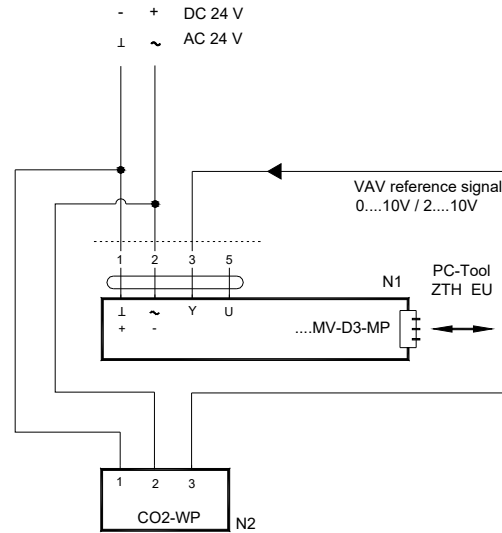
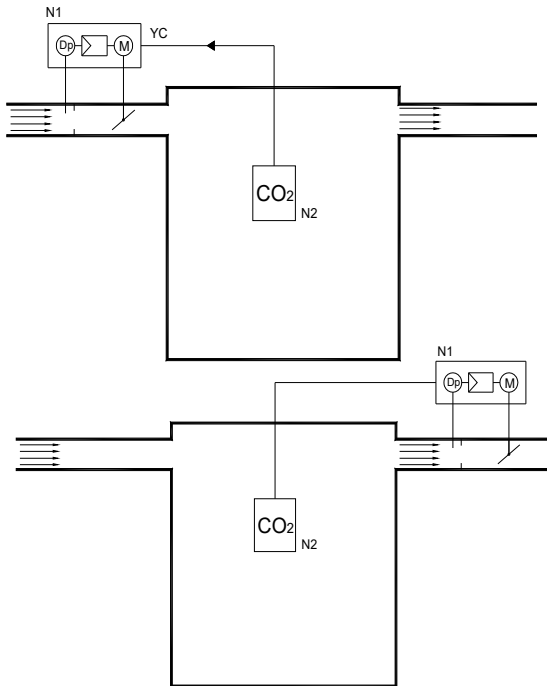

	Concentración de CO ₂ (ppm)	
	Rango	valor por defecto
IDA 1 Calidad alta	≤ 400	350
IDA 2 Calidad media	400...600	500
IDA 3 Calidad moderada	600...1.000	800
IDA 4 Calidad baja	> 1.000	1.200

350 ppm :Concentración media en aire exterior.

500 a 800 ppm :Condiciones de bienestar en los edificios.

1.500 ppm :Límite de bienestar en los edificios.

Commissioning. Jumper Position.

	J1	J2
0-10 VDC(default)	disconnected	disconnected
2-10 VDC	connected	disconnected

	J3
PID out put (default)	disconnected
Linear output	connected

	J4	J5
350 ppm	disconnected	disconnected
500 ppm	connected	disconnected
800 ppm (default)	disconnected	connected
1200 ppm	connected	connected

Communicative VAV Air control.

Wiring diagram **BELIMO**

Air supply control.

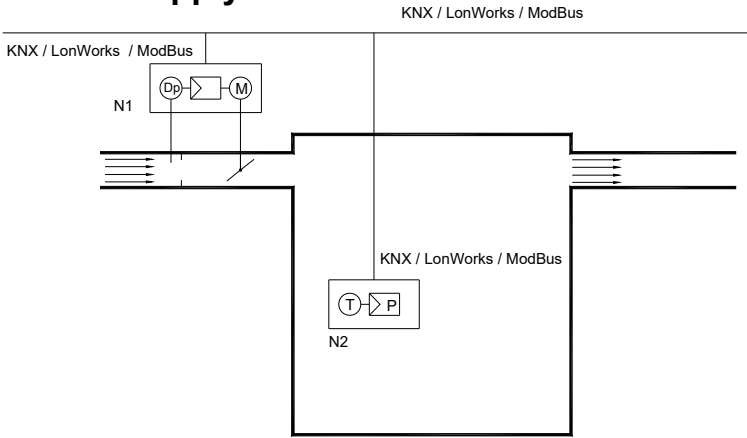

N1 -VAV compact air flow controller with actuator and pressure sensor

N2 Room temperature controller with sensor

Air supply and exhaust control.

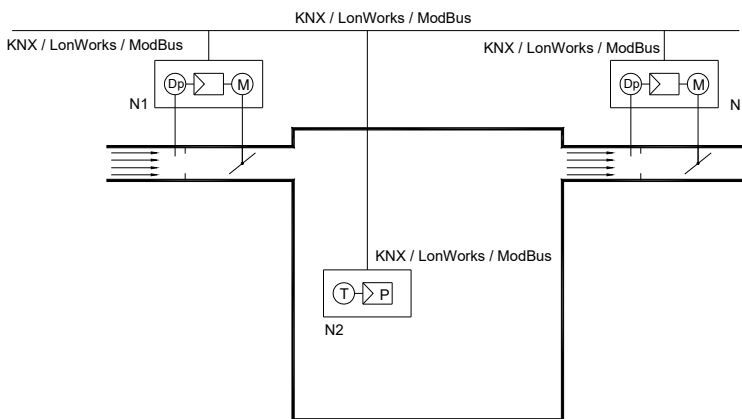

N2SVA-C /LMV-D3-MOD/

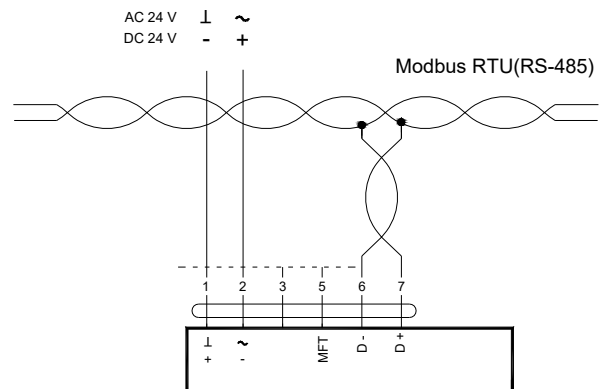

N2SVA-C/LMV-D3LON/

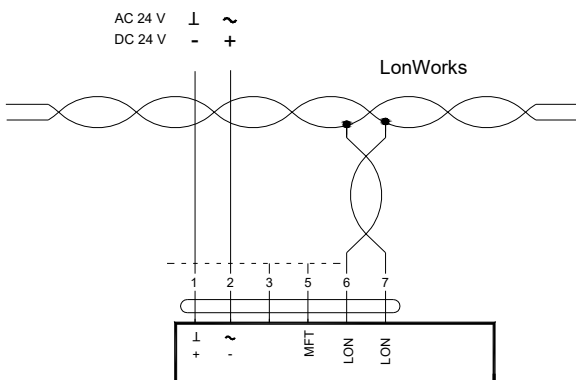

N2SVA-C/LMV-D3-KNX/

