

OTO CURVED VENTS SWIRL DIFFUSERS

MADEL®

The swirl diffusers of **OTO** Series are designed to be used in air conditioning, ventilation and heating systems at a temperature differential up to 12°C.

They can be mounted in false ceilings or suspended from the ceiling, from 2,6 up to 4 metres high.

The **OTO** diffusers allow a flow variation of 60% keeping the air stream stable.

The radial configuration of its eight sections produces a rotational induction of air with Coanda effect and the high airflow rate reduces stratification.

The particular design of the vents creates a uniform airflow along the length of each aperture.

As a result of the collaboration with **Lievore, Altherr & Molina**, the original design of the **OTO** diffusers allows manufacture from a continuous sheet, without any edges which highlight an assembled construction. This results in very smooth airflow characteristics, optimising its design function and reducing the visual impact within the architectural surroundings.

OTO - S

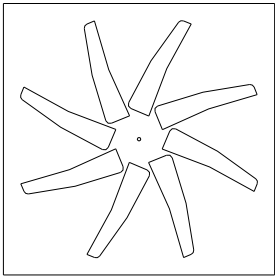

	E	A
600	595	576
625	620	601

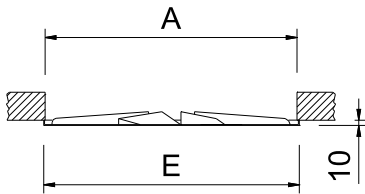

/ T /

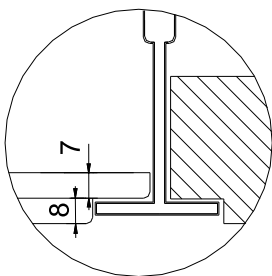
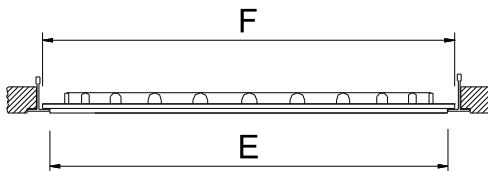

OTO-S / T /

	E	F
600	572	593
625	602	623

OTO - C

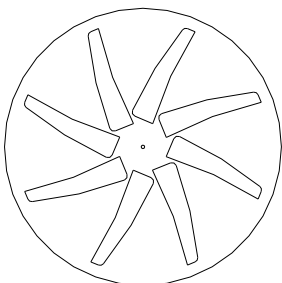

	E	A
625	625	601

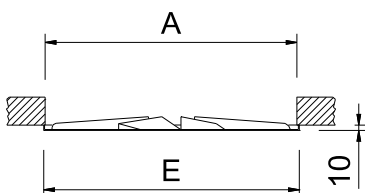

CLASSIFICATION

OTO-S Square diffuser.

OTO-S/T/ Square diffuser with angled borders.

OTO-C Circular diffuser.

MATERIAL

Diffuser constructed from galvanised steel.

All diffusers are provided with a seal on the back of the frame in order that the perimeter in contact with the plenum box or ceiling is airtight.

ADDITIONAL ACCESSORIES

BOXSTAR Plenum box with a lateral circular connection for **OTO-S...** diffusers. It includes supports to hang from the ceiling. The crossbar is supplied separately to be assembled manually on the work site. Made in galvanised steel.

Plenum box to pile up. It spares more than 50 % volume in relation to a conventional plenum box.

...-R Plenum box with a flow damper in the spigot.

.../AIS/ Plenum box thermo acoustically insulated by a foam with a coefficient of thermal conductivity of 0,04 w/mk. This foam complies with the fire reaction specifications:

UNE 23-727 M2

NFP 92-501 M2

DIN 4102 M2

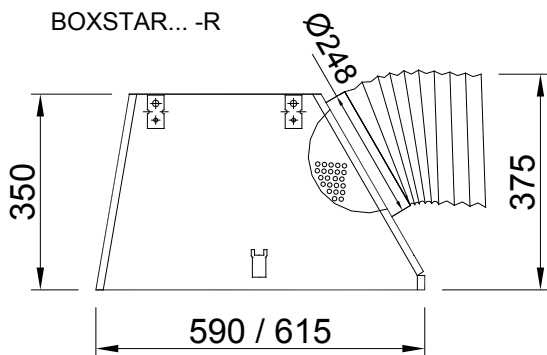

BOXSTAR/S/

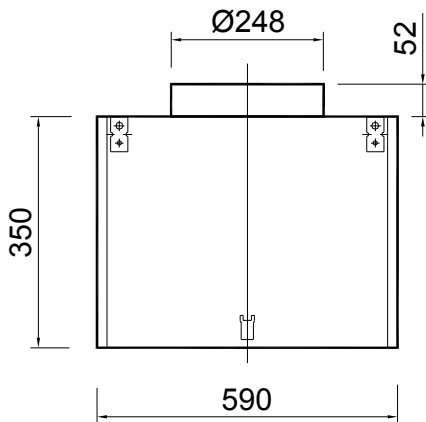

BOXSTAR/S/ Plenum box with an upper circular neck connection for **OTO-S...** diffusers.

It includes supports to hang from the ceiling. Made in galvanised steel.

...-R Plenum box with a flow damper in the spigot.

.../AIS/ Plenum box thermo acoustically insulated by a foam with a coefficient of thermal conductivity of 0,04 w/mk. This foam complies with the fire reaction specifications:

UNE 23-727 M2

NFP 92-501 M2

DIN 4102 M2

PLXOC... - R

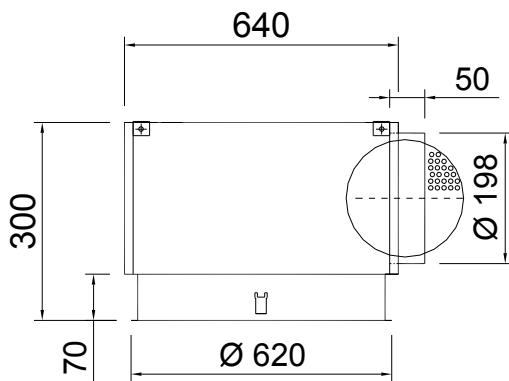

PLXOC Plenum box with a lateral circular connection for **OTO-C** diffusers. Made in galvanised steel.

...-R Plenum box with flow damper in the spigot.

.../S/ Plenum box with an upper connection.

.../AIS/ Plenum box thermo acoustically insulated by a foam with a coefficient of thermal conductivity of 0,04 w/mk. This foam complies with the fire reaction specifications:

UNE 23-727 M2

NFP 92-501 M2

DIN 4102 M2

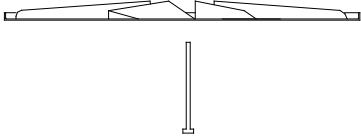
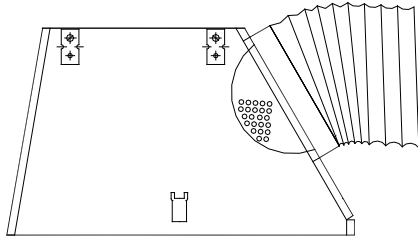

(PMXO)

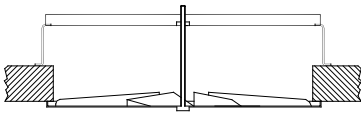

FIXING SYSTEMS

1) Connection into the plenum box by means of central screw, to hang the assembly from the ceiling with drops rods.

1) Connection into the **PMXO** crossbar by means of central screw. Suitable for mounting in false ceiling with rectangular duct. Constructed in galvanised steel.

FINISHES

R9010 Lacquer in white colour RAL 9010.

M9016 Lacquer in white colour similar to RAL 9016.

RAL... Lacquer in other colours (RAL specifications).

OTO SERIES

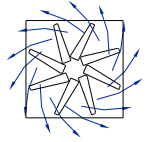

RECOMMENDED VELOCITY.

OTO	Vmin m/s	Vmax m/s
600	2.5	4
625	2.5	4

FREE FACE AREA (m²).

OTO	Afree m ²	Qmin. m ³ /h	Qmax. m ³ /h
600	.0397	357	580
625	.0397	357	580

CORRECTION FACTOR FOR Dpt and LWA1.

BOXSTAR-R		100% Open	50% Open	10% Open
600	Dpt (Kp)	1	1.2	3.1
	Lwa1 (Kf)	+0,7	+3,5	-2,6
625	Dpt (Kp)	1	1.2	3.1
	Lwa1 (Kf)	+0,8	+2,7	-0,6

$$Dpt1 = Kp \times Dpt$$

$$Lwa = Lwa1 + Kf$$

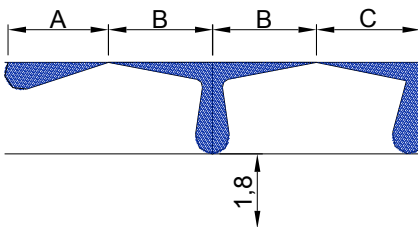

$$AL_{0.2} = A$$

$$AL_{0.2} = B + H$$

$$AL_{0.2} = C + H$$

FREE VELOCITY, PRESSURE LOSS, SOUND POWER LEVEL AND THROW WITH CEILING EFFECT.

OTO-S + BOXSTAR

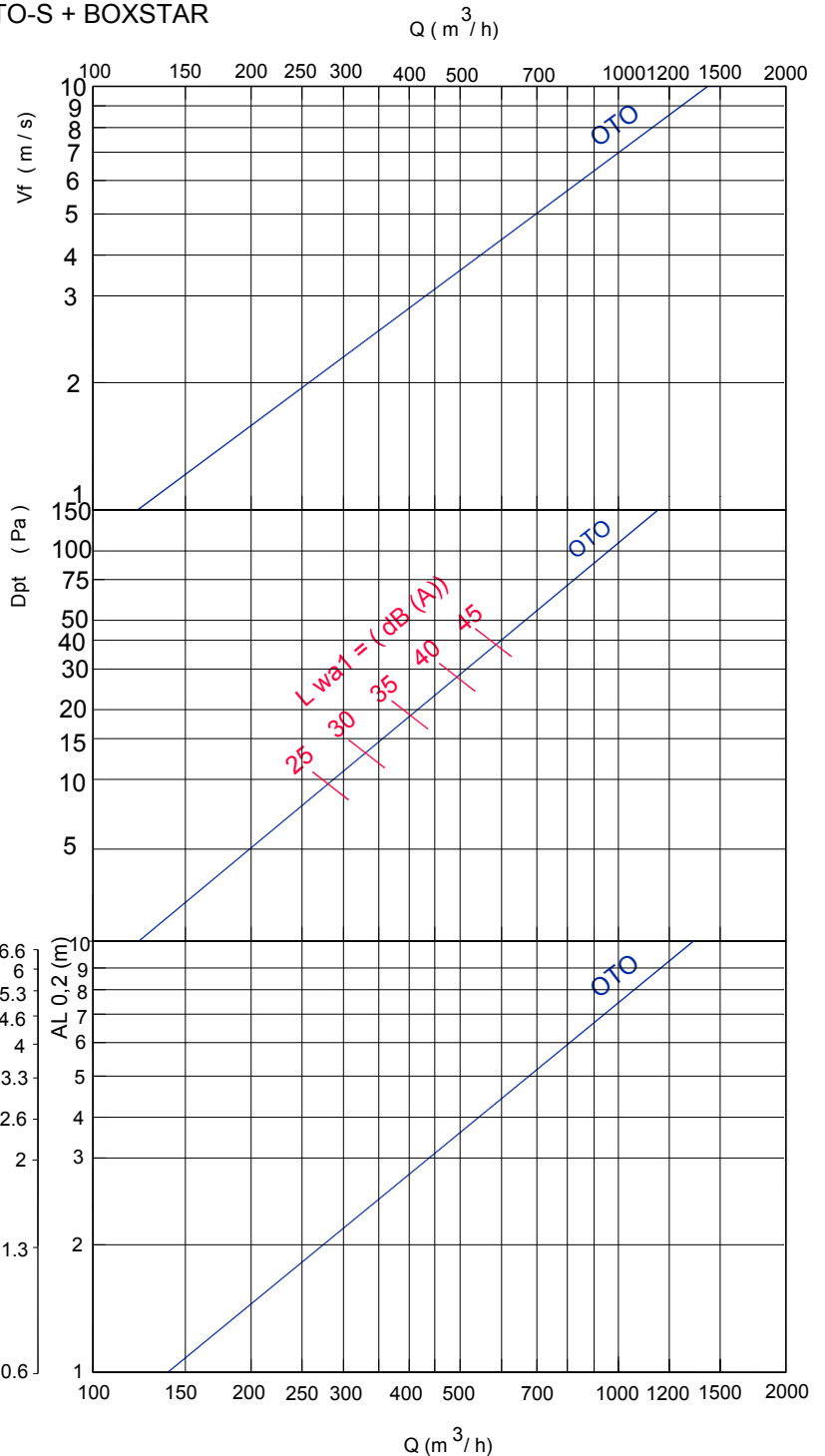

Note: In MadelMedia Octava band centre frequency in Hz.

OTO SERIES

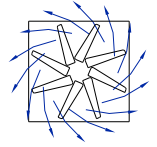

CORRECTION FACTOR FOR VERTICAL DIFFUSION (bv) FOR DT (-).
 Kh = Correction factor for vertical diffusion.

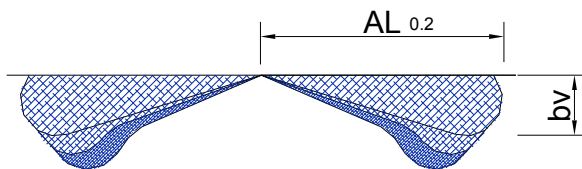
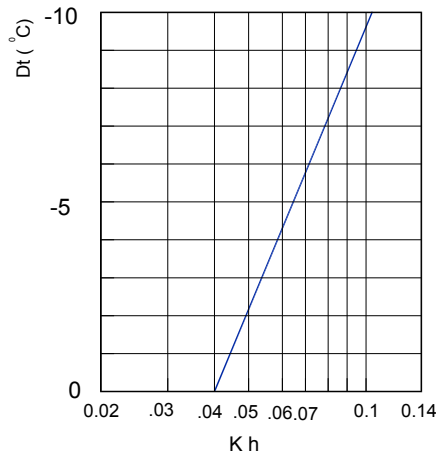

CORRECTION FACTOR FOR THROW (L 0,2) DT (-).
 Kl = Correction factor for throw.

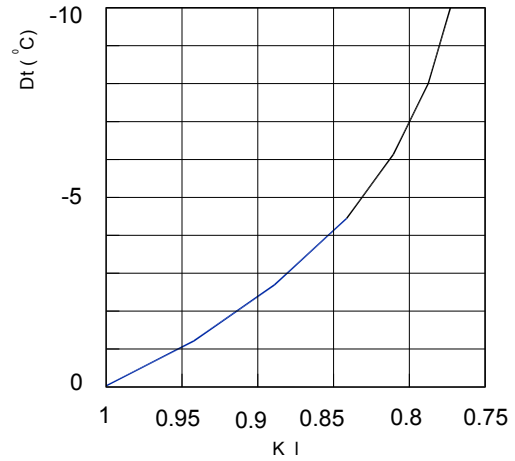

$$bv = Kh \times AL_{0.2}$$

$$AL'_{0.2} (Dt < 0) = Kl \times AL_{0.2}$$

TEMPERATURE RATIO.

$$\frac{Dtl}{Dtz} = \frac{t_{\text{room}} - t_x}{t_{\text{room}} - t_{\text{supply}}}$$

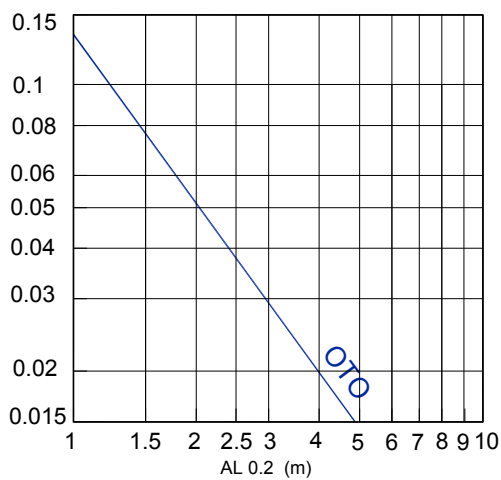

INDUCTION RATIO.

$$i = \frac{Q_r}{Q_0} = \frac{Q_{\text{total at } x}}{Q_{\text{of supply}}}$$

